

INSTRUCTION MANUAL . . . MODELS TNEC, TNECM, TNSC & TNSCM

1.0 GENERAL INFORMATION

1.1 RECEIVING AND UNPACKING

Handle and unpack the equipment carefully. Immediately upon arrival, check the shipment against the packing list. Any damage should be reported immediately to the carrier and to the nearest CMC representative.

Equipment which will not be installed immediately should be stored in a clean, dry location. Precautions should be taken to prevent moisture, dust and dirt from accumulating in storage and installation areas

1.2 PRECAUTIONS

1.2.1 Shipping - It is recommended that the transducer be removed when the machine is transported. If the transducer is left on the machine, the sensing roll should be removed as the shock and vibration transmitted to the transducer by the sensing roll during transporting can damage the transducer.

1.2.2 Overloading - Repetitive overloading above the maximum working force or severe overloading should be avoided because it will damage the transducer.

1.2.3 Applying Tension Force - The pulley or roller to which the tension force is applied should be as close to the face of the transducer as practical in order to obtain the maximum overload protection and best performance. It is recommended that the operating parameters do not exceed the maximum values shown in Figure 1.

TRANSDUCER MWF - LBS	RECOMMENDED MAXIMUM LIMITS		
	ROLL WEIGHT POUNDS	ROLL WIDTH INCHES	SPEED RPM
5	1.00	2.00	3500
10	1.75	3.00	4000
15	2.50	3.50	4000
25	4.00	3.50	4250
50	8.00	3.25	4500
75	12.00	3.00	4500
100	15.00	3.00	4500
150	25.00	2.50	4500

Figure 1

1.3 SPECIFICATIONS

- Gage Resistance - 120 ohms per leg
- Gage Factor - 100 nominal
- Excitation Voltage - 5.6 VDC or VAC (RMS) maximum
- Output Signal at Rated MWF - 250 mV nominal per Transducer (1/2 bridge)
500 mV nominal per Transducer pair (full bridge)
- Output Impedance - Approximately 850 ohms per Transducer at 25°C
- Required Input Impedance of Tension Amplifier - 5K ohms per Transducer
- Maximum Voltage, Gage to Beam or Base (Ground) - 50 VDC
- Operating Temperature Range - 0°F to +200°F

1.4 DESCRIPTION

The type TNEC-1T, TNSC-1T, TNECM-1T and TNSCM-1T transducers can be used to measure tension in a wire, filament, or tape; or they can also be used as load cells. The end of the transducer is provided with a 5/8 inch diameter X 1 inch deep hole to accept a 5/8 diameter shaft to which a pulley can be mounted. The end of the TNEC-1T and TNECM-1T transducer is provided with a 10 mm deep hole to accept a 15 mm shaft to which a pulley can be mounted. Two set screws at 90° to each other are used to lock the shaft in place.

1.0 GENERAL INFORMATION

The different configurations are made by adding mounting hardware modules to the transducer cartridges. In each of the sizes, the transducer cartridges are available with the connector mounted either on the side or the end. For dimensions of the transducer with the mounting kits installed, see Figure 3.

The TNSC-1T and TNSCM-1T cartridges have the connector located on the side. These cartridges can be mounted to the machine frame with a single bolt which goes through the machine frame for the type "S" mounting, as shown in Figure 2.

The flange mounting kit can be clamped onto the groove near the edge at the end of the type cartridge. The TNSC-1T and TNSCM-1T cartridge can then be mounted to the machine frame by the flange with four mounting bolts for the type "FL" mounting, as shown in Figure 2.

The type TNEC-1T and TNECM-1T cartridges have the connector located on the end. The cartridge can be converted to a pillow block type transducer by adding the pillow block (PB) mounting kit. The cartridge is inserted into the pillow block base and then the lockplate is bolted to the end of the cartridge. The transducer is mounted to the machine frame with two bolts through the pillow block base for the type "PB" mounting, as shown in Figure 2.

The type TNEC-1T AND TNECM-1T cartridges can also be mounted through the machine frame by using the type BR mounting kit. The cartridge is inserted through a hole in the machine frame and then the lockplate is bolted to the end of the cartridge for the type "BR" mounting, as shown in Figure 2.

For mounting dimensions see Figure 3.

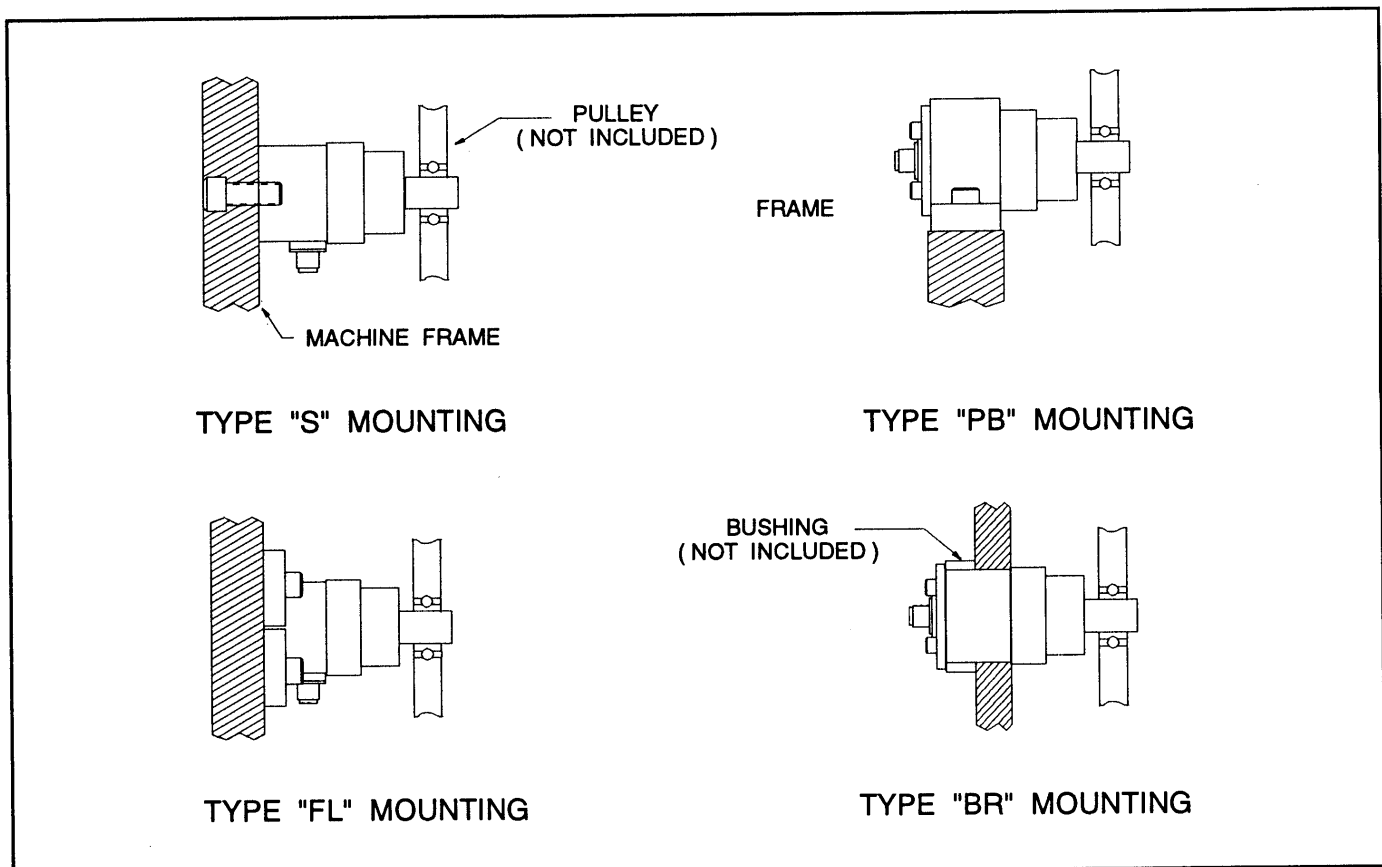
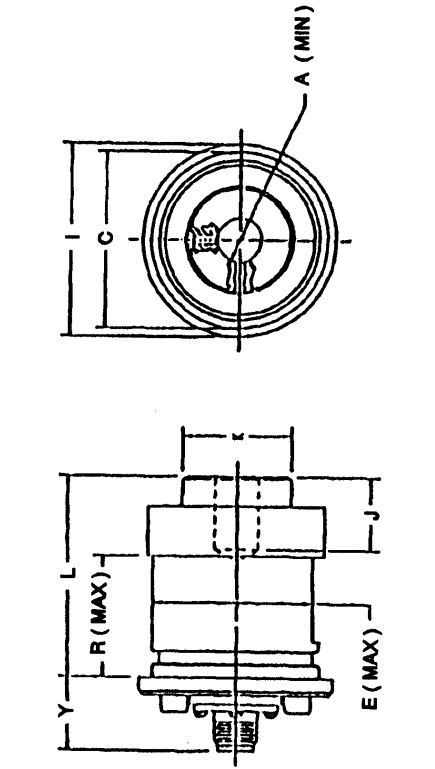
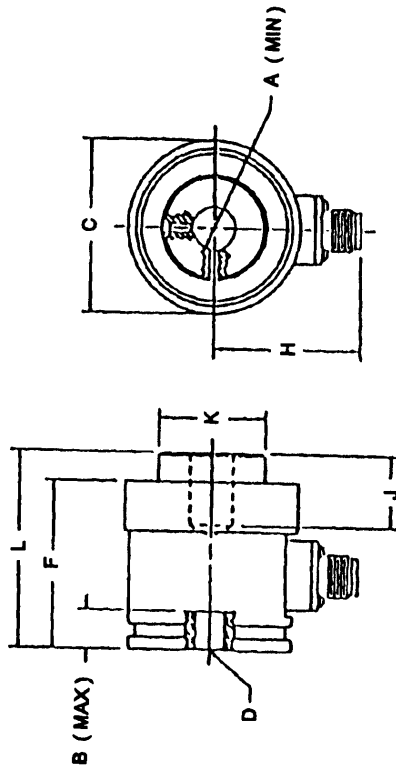

Figure 2

1.0 GENERAL INFORMATION



TYPE TMSC CARTRIDGE WITH FL MOUNTING KIT



TYPE TMSC CARTRIDGE

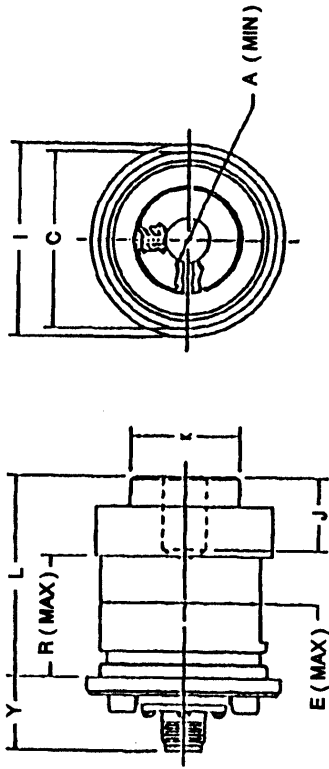

TYPE TNEC CARTRIDGE WITH BR MOUNTING KIT

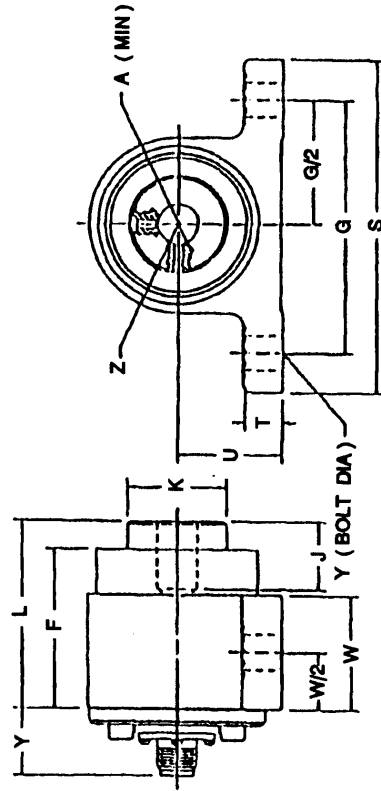

TYPE TNEC CARTRIDGE WITH PILLOW BLOCK MOUNTING KIT

		DIMENSIONS IN INCHES ALLOW 2.5 IN. CLEARANCE FOR CONNECTOR																						
SIZE	A	B	C	D	E	F	H	I	J	K	L	M	N	O	P	Q	R	S	T	U	V	W	Y	Z
1T	0.625	0.55	2.50	1/2-13	2.375	2.44	2.10	2.75	1.03	1.55	2.88	3/8	3.25	0.50	4.00	4.00	1.74	5.38	0.58	1.63	1.02	1.75	1/2	1.50
		DIMENSIONS IN MILLIMETERS ALLOW 64mm CLEARANCE FOR CONNECTOR																						
SIZE	A	B	C	D	E	F	H	I	J	K	L	M	N	O	P	Q	R	S	T	U	V	W	Y	Z
M-1T	15.0	14.0	63.5	M12-1.75	60.32	62.0	53.3	69.9	26.2	39.4	73.2	M-10	82.6	12.7	101.6	101.6	44.2	136.7	14.7	41.3	25.9	44.5	M-12	38.1

OUTLINE DIMENSIONS

Figure 3

2.0 INSTALLATION

2.1 SELECTION OF TRANSDUCER MOUNTING LOCATION

When selecting a transducer mounting location, keep in mind that the tension sensing pulley must NOT be mounted where the web wrap angle can vary. Any change in the wrap angle will be sensed by the transducer as a change in tension, and indicated as such on the tension indicator.

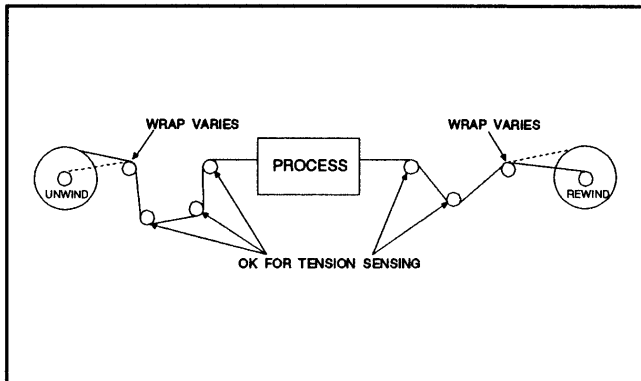

Figure 4

In some cases, it may be impossible to find a location for the transducer where the wrap angle does not vary. The change in indicated tension which will result can be calculated and, if small, may not be significant.

2.2 MOUNTING SURFACE PREPARATION

The mounting surfaces for the transducer should be flat. Prepare the machine frame or mounting surface by removing any loose paint, rust, scale, etc.

2.3 GENERAL INSTALLATION INFORMATION

The transducer must be mounted so that the applied web force is in line with the arrow on the load direction label. See Figure 5 and the instructions on pages four and five for your particular transducer type and orientation.

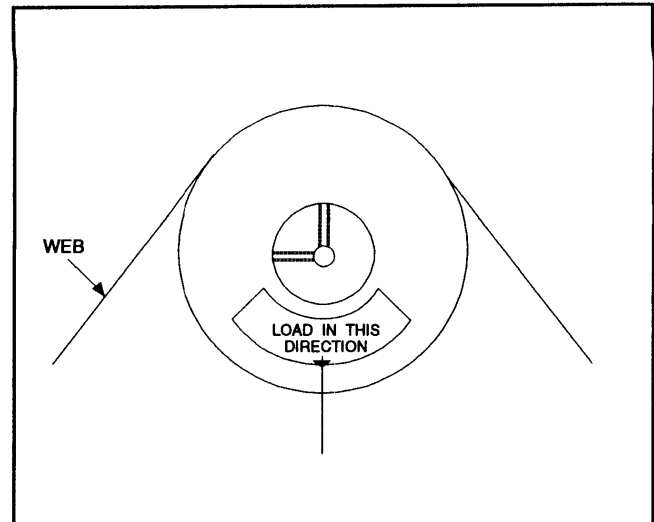

Figure 5

2.4 TYPE S

Before tightening the mounting bolt, rotate the transducer until the load direction arrow is pointing in the direction of the web force. The cable connector should be the bisector of the web wrap angle.

The mounting bolts must not bottom out in the transducer. Measure to check that there is clearance between the mounting bolt and the bottom of the transducer mounting hole. The depth of the mounting hole for Type TNSC-1T is 0.55" and for type TNSCM-1T is 13 mm.

2.5 TYPE PB AND BR

After mounting, loosen - **DO NOT REMOVE** - the four socket head cap screws holding the lockplate on the back of the transducer. The transducer can now be rotated until the web force is in line with the load direction arrow. Firmly tighten cap screws.

2.6 TYPE FL

The mounting holes should be drilled so that the cable connector is in line with the resultant web force and will not interfere with the four transducer mounting bolts. The load direction arrow should bisect the web wrap angle. If present mounting holes are to be used, or if for some reason new holes cannot be drilled, the split flange can be rotated relative to the transducer body.

2.0 INSTALLATION

In order to rotate the split flange, remove the transducer from the machine frame. Loosen the two bolts clamping the split flange to the transducer body. Rotate the split flange to the desired position and then retighten the two clamping bolts. If the load direction arrow is not lined up with the web force, there will be some loss in sensitivity.

3.0 ELECTRICAL CONNECTIONS

Refer to the installation wiring diagrams supplied with the Cleveland-Kidder tension indicator or controller for making the transducer connections. Make certain that the cables do not interfere with the web path and that they are away from gearing or other moving parts.

Figure 6 is for reference only for use with a half bridge one transducer configuration. Many of the Cleveland-Kidder indicators and controllers use only half bridge transducer inputs and then sum the two transducer signals internally. See the applicable installation wiring diagrams for the tension indicator or controller.

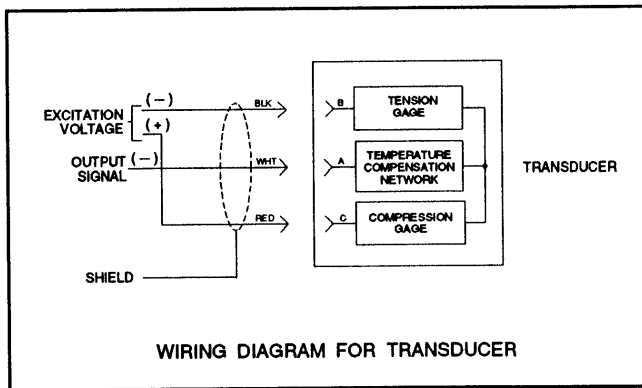

Figure 6

3.1 MATING CONNECTORS FOR TRANSDUCERS

USE	CMC P/N
Mating Straight Connector, Boot and Clamp Kit	MO-09854
Mating 90° Angle Connector, Boot and Clamp Kit	MO-09855

3.2 INTRINSICALLY SAFE TRANSDUCERS

These transducers are intrinsically safe only when they are part of a complete intrinsically safe system using the TIX-1 tension indicator or wired per CMC control drawings.

For transducers utilizing a 5.6 VDC (± 2.8 VDC) excitation voltage refer to CMC Control Drawing A800-42273. For transducers utilizing a +5VDC excitation voltage refer to CMC Control Drawing A800-42281.

Barrier block assemblies and/or the individual barrier blocks may be purchased from CMC. Please contact CMC for part numbers and pricing.

4.0 TEMPERATURE COMPENSATION

The transducer is supplied with a temperature compensation network which is in series with the output signal lead. The compensation circuit is designed to be used with a tension amplifier which has an input impedance of 5K Ohms when a one transducer is used. If other than the input impedances given above are used, drift will occur in the tension amplifier output when the transducer temperature changes.

5.0 TROUBLESHOOTING

5.1 LOW OUTPUT SIGNAL

The transducer may have too large a maximum working force for the application. Replace with a lower maximum working force transducer or increase web wrap angle.

5.2 OUTPUT SIGNAL FAILS TO INCREASE WITH ADDED LOAD

The transducer is overloaded and is hitting the mechanical stop. Replace the transducer with one having a higher maximum working force or reduce the load. This may be accomplished by reducing the web wrap angle.

5.0 TROUBLESHOOTING

5.3 WRONG POLARITY OF OUTPUT SIGNAL

The transducer may have been incorrectly oriented. Rotate the transducer 180 degrees. If rotation is impossible, interchange the transducer leads as instructed in the tension indicator or controller manual.

5.4 NO OUTPUT SIGNAL

Check to see that all connections have been made completely. Check for places where the connecting cable might be crimped or cut.

5.5 VERY HIGH OUTPUT WITH NO LOAD

Check cable and connector for good connections and check continuity of cable with an ohmmeter. Check for proper wiring to transducer. Check transducer gage resistance as given in the following chart at room temperature with no load applied.

TRANSDUCERS GAGE RESISTANCE CHECK

<u>Measurement</u>	<u>Resistance</u>
Pin C to Pin B	240 ohms \pm 36 ohms
Pin A to Pin B	120 ohms \pm 18 ohms
Pin A to Pin C	Equal to Pin A to Pin B \pm 5 ohms

6.0 SERVICE ASSISTANCE AND REPAIR

For additional service assistance, please obtain the Type, MWF, and Serial Number from the nameplate. Contact the Factory Service Department.

Phone: (216) 524-8800

Fax: (216) 642-5155

Disassembly by improperly trained personnel may result in additional damage to this unit. Should repairs be required or for warranty repairs, contact the Customer Service Department for a return authorization number before returning the unit.

7.0 WARRANTY AND LIMITATION OF LIABILITY

LIMITED WARRANTY.

ALL GOODS ARE SOLD SUBJECT TO THE MUTUAL AGREEMENT THAT THEY ARE WARRANTED BY THE COMPANY TO BE FREE FROM DEFECTS IN MATERIAL AND WORKMANSHIP FOR ONE YEAR FROM THE DATE OF SHIPMENT. THE COMPANY'S WARRANTY DOES NOT COVER, AND IT MAKES NO WARRANTY WITH RESPECT TO ANY DEFECT, FAILURE, DEFICIENCY OR ERROR WHICH IS:

- A) NOT REPORTED TO THE COMPANY WITHIN THE APPLICABLE WARRANTY PERIOD; OR
- B) DUE TO MISAPPLICATION, MODIFICATION, DISASSEMBLY, ABUSE, MISUSE, IMPROPER INSTALLATION, UNAUTHORIZED REPAIR, IMPROPER MAINTENANCE OR ABNORMAL CONDITIONS OF TEMPERATURE, DIRT OR CORROSIVE MATTER; OR
- C) DUE TO OPERATION, EITHER INTENTIONAL OR OTHERWISE, ABOVE RATED CAPACITIES OR IN AN OTHERWISE IMPROPER MANNER.

THE FOREGOING WARRANTY IS IN LIEU OF ALL OTHER WARRANTIES. THE PARTIES AGREE THAT THE IMPLIED WARRANTIES OF MERCHANTABILITY AND FITNESS FOR A PARTICULAR PURPOSE AND ALL OTHER WARRANTIES, EXPRESS OR IMPLIED, ARE EXCLUDED FROM THE SALE OF GOODS.

LIMITATION OF REMEDY AND LIABILITY.

THE REMEDY PROVIDED HEREIN IS BUYER'S SOLE AND EXCLUSIVE REMEDY. **THE BUYER'S REMEDY AND THE COMPANY'S LIABILITY (WHETHER UNDER THE THEORIES OF BREACH OF WARRANTY, CONTRACT, TORT INCLUDING NEGLIGENCE OR STRICT LIABILITY OR ANY OTHER LEGAL THEORY) SHALL BE LIMITED EXCLUSIVELY AT THE COMPANY'S OPTION TO REPLACING OR REPAIRING WITHOUT CHARGE AT THE COMPANY'S FACTORY OR ELSEWHERE ANY MATERIAL OR WORKMANSHIP DEFECTS WHICH BECOME APPARENT WITHIN ONE YEAR FROM THE DATE ON WHICH THE GOODS WERE SHIPPED.** THE COMPANY SHALL NOT BE LIABLE FOR SPECIAL, INCIDENTAL OR CONSEQUENTIAL DAMAGES OF ANY KIND INCLUDING BUT NOT LIMITED TO DAMAGES FOR LOSS OF USE, INCOME OR PROFIT, OR LOSSES SUSTAINED AS A RESULT OF INJURY (INCLUDING DEATH) TO ANY PERSON OR DAMAGES TO PROPERTY. THE COMPANY SHALL HAVE NO LIABILITY FOR DAMAGES OF ANY KIND ARISING FROM THE INSTALLATION AND/OR USE OF THE GOODS BY ANYONE. BY THE ACCEPTANCE OF THE GOODS, THE BUYER SHALL ASSUME ALL LIABILITY FOR ANY DAMAGES WHICH MAY RESULT FROM USE OR MISUSE BY THE BUYER, ITS EMPLOYEES OR BY OTHERS.



Blank