

Cleveland-Kidder® Ultra



Performance Benefits

The new family of Cleveland-Kidder® Ultra Line Cartridge-Style Tension Transducers (Load Cells) provide accurate measurement and control of web tension in continuous process machinery applications. These force transducers are easily applied, provide consistent product quality, and are highly responsive for enhanced system performance.

Ultra Line Cartridge-Style Load Cells are modular in design, providing the greatest degree of installation and application flexibility. With heavy duty construction and a low maintenance design, they reduce the necessity of machine modifications while minimizing

downtime. They are ideally suited for lightweight material and thin webs where tight control of tension is required to prevent stretching or wrinkling of the material.

Ultra Line Cartridge-Style Transducers, when used in conjunction with Ultra Line Amplifiers, provide better performance than competitive load cells by increasing the operating tension range from 8:1 to 40:1. They also provide more accurate measurement by eliminating electrical disturbances caused by AC drives, servos, and other modern high frequency devices.

Benefits: Advantages Over Conventional Transducers	Features: Why It Can Be Done	Technical Specifics: How CMC Does It
Operates over a wider tension range. Provides up to 40:1 tension range. Competitive products typically provide tension ranges of only 8:1 or 16:1, at the very best.	Provides a higher output signal which results in better signal resolution.	Full Wheatstone Bridge semiconductor strain gage transducer design provides a higher and more stable signal. "Twin beam" design provides high mechanical gain with negligible displacement.
Ability to measure lower (light) tensions.	Substantial and stable output signal even at low tensions.	New amplifier technology eliminates drift, which distorts low-tension measurements.
Does not react to electrical noise from AC motors, servo, relay coils, or other electrical disturbances.	Rejects electrical noise resulting in clean and accurate output signal devoid of distortion.	Four-wire differential ended technology provides common mode rejection of electrical disturbances.
Better at maintaining proper tension measurement regardless of ambient temperature changes.	Minimum deviation of signal output due to temperature changes.	Precise temperature compensation network cancels out temperature influences.

TENSION TRANSDUCERS

CARTRIDGE-STYLE

ULTRALINE*

Modular Force Transducers (Load Cells) Providing up to a 40:1 Tension Range.

- Provides up to a 40:1 Tension Range (Ex: Accurately measures from 1.25 lbs. to 50 lbs. of tension when used with a 50 lb. rated Ultra Load Cell and Ultra Amplifier).
- Rejects electrical noise from AC motors, servos, relay coils, or other electrical disturbances.
- Available in 25 lb. to 1000 lb. load ratings.
- Variety of mounting kits for convenient installation.
- Easily oriented at any angle—for all web paths.
- Able to measure lower (light) tensions.
- Maintains proper tension measurement regardless of changes in ambient temperature.
- Accommodates shaft expansion and shaft misalignment up to 1°.
- Corrosion-resistant finish and dust seal.
- Built-in overload stop.

CE

www.ClevelandKidder.com

CMC Cleveland
Motion Controls
An IMC Company

TENSION TRANSDUCERS

Cleveland-Kidder® Ultra

CARTRIDGE-STYLE

MOUNTING CONFIGURATIONS

Ultra Series Cartridge-Style Transducers can be mounted either inside the frame, on top, or through the frame of the machine, depending on the model type purchased. Two transducers are required per tension roller, with one positioned on either side of the roller.

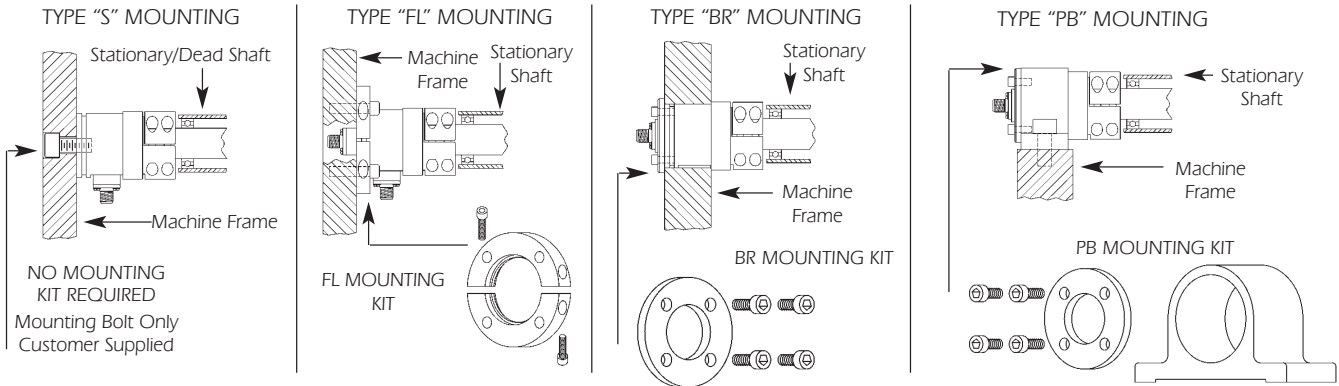

Mounting Type And Connector Compatibility

When Using This Type of Mounting Configuration:	The Connector can be located at:	
	End (EC)	Side (SC)
Flange (FL)	X	X
Stud (S)		X
Pillow Block (PB)	X	
Bearing Replacement (BR)	X	

TRANSDUCER CARTRIDGE TYPES

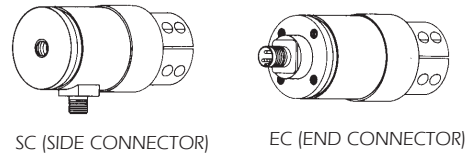

SPECIFICATIONS

	1T	2T	3T			
Transducer Weight	2.9 lbs. 1.32 kg.	4.0 lb. 1.81 kg.	5.0 lbs. 2.27 kg.	Excitation Voltage	5.6 VDC or VAC (RMS) maximum (Excess voltage can cause permanent damage)	
Weight + Mounting Kit	Flange	3.9 lbs. 1.77 kg.	5.6 lbs. 2.54 kg.	6.6 lbs. 2.99 kg.	Nominal Output Signal at Rated MWF	±350 mV per Transducer (with 5 VDC or VAC ms excitation voltage)
	Bearing Replacement	3.3 lbs. 1.50 kg.	4.5 lbs. 2.04 kg.	5.5 lbs. 2.49 kg.	Output Impedance	Approximately 64 Ohms per Bridge leg
	Pillow Block	5.8 lbs. 2.63 kg.	8.2 lbs. 3.72 kg.	9.2 lbs. 4.17 kg.	Non-destructive Overload	150% MWF
Material	Strain Sensing Beam– Heat Treated 4140 Alloy Steel Body– 1117 Low Carbon Steel			Ultimate Overload	300% MWF (typ)	
Finish Material	Corrosion resistant Zinc plated with Clear Chromate			Maximum Voltage, Gage to Beam or Base (Ground)	50 Volts peak	
Bridge Resistance	135–147 Ohms @ 20° C			Operating Temperature Range	0° F to +200° F	
Gage Type	Semi-conductor strain gage, gage factor= 95 (nom.)			Alignment	± 1 degrees angular displacement	
Connector Type	M12 Quick-disconnect, 4 conductor, DC keyed			Accommodation of Shaft Expansion/Contraction	± 0.04 inches (± 1 mm) per transducer	

SELECTING A CARTRIDGE-STYLE TRANSDUCER FOR YOUR APPLICATION

Determine the MWF using the following equation:

$$MWF = \frac{2T \times K \times \sin(A/2) \pm W \times \sin(B)^*}{2}$$

- MWF = Maximum Working Force (lbs.)
- T = Maximum Total Tension (lbs.)
- K = Transient Tension Overload Factor (normally between 1.4 and 2.0)
- A = Wrap Angle (Degrees)
- B = Angle of Tension Force (Degrees)
- W = Weight of Roller (lbs.)

* Use + if Angle B is below horizontal and – if above horizontal.

Contact CMC application engineering to assist you in selecting the appropriate transducer.

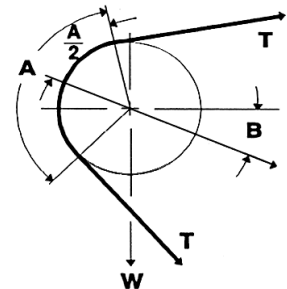

INDUSTRIAL PRODUCTS

7550 Hub Parkway
Cleveland, Oh 44125-5794
Tel: 216.524.8800 or 800.321.8072
Fax: 216.642.2199
www.cmcontrols.com

www.ClevelandKidder.com



HOW TO ORDER

If you need to purchase a Transducer, Mounting Kit, Split Bushing and Cable corresponding to the following description:	Use The Following Catalog Numbers:
<ul style="list-style-type: none"> Maximum Working Force (MWF) of 150 lbs.— Size 2 Body Bore Diameter of 1.25 inches (To allow direct use of Cleveland-Kidder Split Bushings) Side Connector (To allow Flange Mounting) 	Ultra Series Transducer = MO-13327-00 (Refer to Table A) Mounting Kit = MO-04498 (Refer to Table B)
<ul style="list-style-type: none"> Bushing to accommodate 3/4 inch (Outside Diameter) Shaft 	Split Bushing = MO-00988-1 (Refer to Table C)
<ul style="list-style-type: none"> 8 Meter (26 ft.) Cable 	Cable = X44-33975-026 (Refer to Table D)

TABLE A – Determining A Catalog Number For The Ultra Stationary Shaft Transducer

Cartridge Size	Bore Diameter of Shaft Coupling (Inches)	Side Connector (SC)	End Connector (EC)	Order Code Suffix–M.W.F				
				-00	-10	-20	-30	-40
1T	1.25	MO-13333	MO-13332	25 lb.	50 lb.	75 lb.	100 lb.	150 lb.
1T	1.50	MO-13335	MO-13334					
2T	1.25	MO-13327	MO-13326	150 lb.	250 lb.	400 lb.	600 lb.	1000 lb.
2T	1.50	MO-13329	MO-13328					
3T	1.94	MO-13331	MO-13330					
Metric								
Cartridge Size	Shaft Diameter (millimeters)	Side Connection (SCM)	End Connection (ECM)	Order Code Suffix–Metric M.W.F				
				-00	-10	-20	-30	-40
1T	30	MO-13431	MO-13429	100 N	200 N	350 N	450 N	650 N
2T	30	MO-13432	MO-13430	650 N	1000 N	1800 N	2500 N	4500 N

TABLE B – Determining A Mounting Kit Catalog Number For The Ultra Series Cartridge Transducer

Mounting Style	Size			
	1T (Inch)	2T or 3T (Inch)	1T (millimeter)	2T or 3T (millimeter)
Bearing Replacement (BR)	M0-04495	M0-04500	M0-05175	M0-05174
Flange (FL)	M0-04493	M0-04498	M0-05176	M0-05177
Pillow Block (PB)	M0-04494	M0-04499	M0-05172	M0-05173

TABLE C – Determining A Split Bushing Catalog Number For The Ultra Series Cartridge Transducer

If Finished Bore Diameter (Nominal I.D.) equals:	Use Catalog Number	Additional Information
1/2 inch	MO-00988-7	All Cleveland-Kidder Split Bushings have Outside Diameter of 1.25 inches
5/8 inch	MO-00988-0	
3/4 inch	MO-00988-1	
7/8 inch	MO-00988-2	
1 inch	MO-00988-3	
1-1/8 inch	MO-00988-4	
1-3/16 inch	MO-00988-5	
15 millimeter	MO-00988-9	
20 millimeter	MO-00988-6	
25 millimeter	MO-00988-8	

TABLE D – Determining A Cable Catalog Number For The Ultra Series Cartridge Transducer

The load cell end of the cordset is provided with a straight or right angle M12 Quick-Connect Sealed 4-pin keyed Connector as specified. The controller/amplifier end of the cordset is provided with flying leads (4 signal and 1 shield drain). The controller/amplifier end of the cable can be cut to length by the customer if the standard lengths provided are not the exact lengths required.

Cable Length	Part Number–Straight Connector	Part Number–Right Angle Connector
26 Feet (8 meters)	X44-33975-026	X44-33976-026
52 Feet (16 meters)	X44-33975-052	X44-33976-052
78 Feet (24 meters)	X44-33975-078	X44-33976-078
105 Feet (32 meters)	X44-33975-105	X44-33976-105
157 Feet (40 meters)	X44-33975-157	X44-33976-157

INDUSTRIAL PRODUCTS

7550 Hub Parkway
 Cleveland, Oh 44125-5794
 Tel: 216.524.8800 or 800.321.8072
 Fax: 216.642.2199
 www.cmcccontrols.com

www.ClevelandKidder.com



CARTRIDGE-STYLE

MOUNTING DIMENSIONS

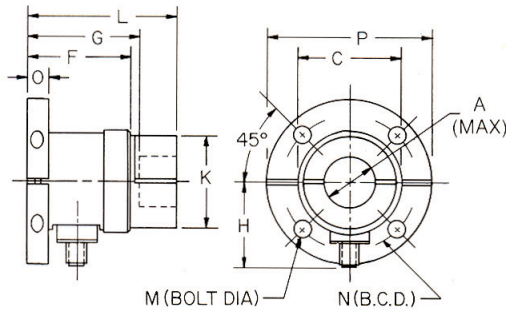

ULTRA SC/SCM CARTRIDGE WITH FL MOUNTING KIT

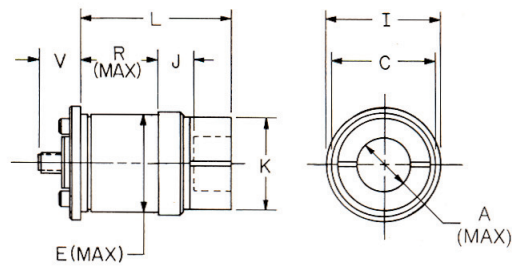

ULTRA EC/ECM CARTRIDGE WITH BR MOUNTING KIT

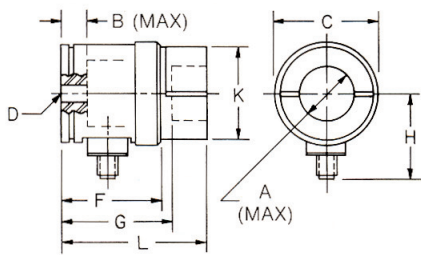

ULTRA SC/SCM CARTRIDGE

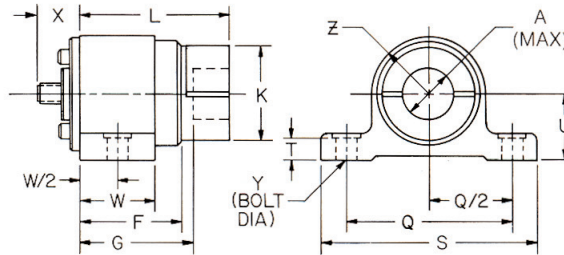

ULTRA EC/ECM CARTRIDGE WITH PB MOUNTING KIT

Mounting Dimensions In Inches: EC and SC

Designator	1T	2T	3T
A* Standard Bore Dia.	1.250	1.250	1.938
1.50 in. Bore Dia.	1.50	1.50	
B	0.55	0.60	0.60
C	2.50	2.75	2.75
D	1/2-13	5/8-11	5/8-11
E	2.375	2.625	2.626
F	2.44	2.85	2.85
G	2.60	2.98	3.48
H	2.10	2.23	2.23
I	2.75	3.00	3.00
J	0.87	1.11	1.61
K Standard Bore Dia.	2.25	2.25	2.95
1.50 in. Bore Dia.	2.50	2.50	
L	3.63	4.04	4.54
M	3/8	1/2	1/2
N	3.25	3.50	3.50
O	0.50	0.62	0.62
P	4.00	4.50	4.50
Q	4.00	5.00	5.00
R	1.74	1.87	1.87
S	5.38	6.12	6.12
T	0.58	0.68	0.68
U	1.63	1.94	1.94
V	1.02	1.02	1.02
W	1.75	1.88	1.88
X	1.02	1.02	1.02
Y	1/2	1/2	1/2
Z	1.50	1.70	1.70

*Bushings are available for smaller shaft diameters

**Mounting Dimensions In Millimeters:
ECM and SCM**

Designator	1T	2T
A*	30.00	30.00
B	14.0	15.2
C	63.5	69.9
D	M12-1.75	M16-2
E*	60.32	66.67
F	62.0	72.4
G	66.0	75.7
H	53.3	56.6
I	69.9	76.2
J	22.1	28.2
K	57.2	57.2
L	92.2	102.6
M	M-10	M-12
N	82.55	88.90
O	12.7	15.9
P	101.6	114.3
Q	101.6	127.0
R	44.2	47.5
S	136.7	155.4
T	14.7	17.3
U	41.3	49.2
V	25.9	25.9
W	44.5	47.6
X	25.9	25.9
Y	M-12	M-12
Z	38.1	43.2

*Bushings are available for smaller shaft diameters

INDUSTRIAL PRODUCTS

7550 Hub Parkway
Cleveland, OH 44125-5794
Tel: 216.524.8800 or 800.321.8072
Fax: 216.642.2199
www.cmccontrols.com

www.ClevelandKidder.com

