



ITT

Cleveland Motion Controls



ENCODERS SHAFT-TYPE

DataTorque™ SM16

Performance Benefits

Cleveland Motion Controls is widely recognized for providing high performance shaft and motor-mounted DataTorque™ Encoder solutions. The CE Compliant DataTorque SM16, with IP65 ratings, is no exception.

By combining high performance, advanced design, proven reliability and low cost, the DataTorque SM16 is an ideal industrial encoder to meet a wide variety of application requirements. It meets all of the requirements of EIA standard RS-422 while retaining low power characteristics of CMOS, enabling the construction of serial and terminal interfaces while maintaining minimal power consumption.

All DataTorque Encoders can be custom configured to meet specific, high volume OEM requirements. We can accommodate many specialized combinations of electrical and mechanical interfaces. Please consult our experienced team of application engineers for details on custom OEM products.

Design Features

The DataTorque SM16 Encoder is manufactured with precision surface mount technology. It utilizes high precision, spindle grade ball bearings (sealed), providing a rugged encoder within its design as well as a liquid tight, nickel plated brass cable seal.

The DataTorque SM16 Encoder incorporates the 2631 series quad differential line driver, designed for digital data transmission over balanced lines.

The SM16 utilizes a monolithic solar array with stop gap diffusion, providing further noise immunity. The differential array tracks evenly under temperature, voltage and light source variations.

The DataTorque SM16 is an optical incremental encoder with resolution of 1-2500 CPR (cycles per revolution). It is accurate to ± 6 arc seconds (pulse to adjacent pulse) and ± 3 arc minutes (pulse to any other pulse).



Low Cost Optical Incremental Industrial Encoder with IP65 Ratings

- High performance that costs less
- Precision surface mount technology
- Rugged design utilizing high precision spindle grade bearings
- Noise immunity with monolithic solar array
- Incorporates 2631 differential line driver for digital data transmission over balanced lines
- Enables the construction of serial and terminal interfaces while maintaining minimal power consumption
- Numerous built-in design features and performance benefits enable the SM16 to meet or exceed any other competitive encoder on the market today.
- CE compliant



DataTorque™ SM16

CW VIEWING SHAFT OUTPUT SIGNALS

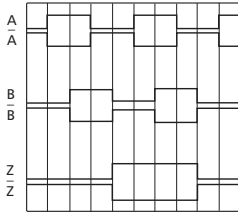

PACKAGE DIMENSIONS

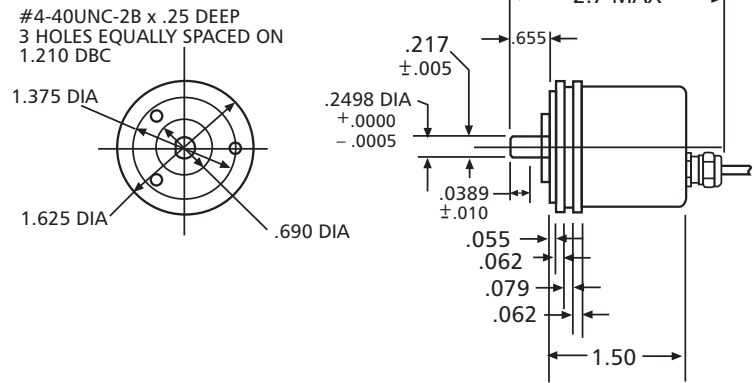

ELECTRICAL SPECIFICATIONS

Encoder Type	Optical Incremental, IP65 Ratings
Resolution	1-2500 CPR (cycles per revolution)
Power Input	3.3 VDC ~ 24 VDC (specify when ordering)
Phase Relationship	A leads B by 90 degrees ±18 degrees electrical
Symmetry	180 degrees ±9 degrees
Illumination Source	Single Infrared Emitting Diode (IRLED) Gallium Aluminum Arsenide (GaAlAs)
Frequency Response	200 kHz or 3,000 RPM, whichever occurs first
Drive Capability	RS-422A compatible
Output Mode	2631 series
Accuracy	Pulse to Adjacent Pulse: ±6 arc seconds Pulse to Any Other Pulse: ±3 arc minutes

TERMINATIONS

Color Code: Standard		Color Code: Differential Line Driver	
Red	+VDC	Green	A output
Black	Ground	Yellow	Z output
Green	A out	White	B output
White	B out	Red	+VDC
Yellow	Z out	Black	Ground
		Blue	A output
		Brown	B output
		Orange	Z output

ENVIRONMENTAL SPECIFICATIONS

Operating Ambient	-10 to +70 degrees C
Storage Ambient	-30 to +80 degrees C
Vibration	50 Hz - 10 G - 1 Hr
Shock	30 G 11 ms

MECHANICAL SPECIFICATIONS

Front End	Anodized Aluminum
Cover	Anodized Aluminum
Bearings	Sealed Instrument Quality (IP65 Rated)
Bearing Life	2.8 X 10 ⁹ revolutions
Shaft	1/4 inch stainless steel with flat
Operating Speed Max.	3,000 RPM or 200 kHz, whichever occurs first
Slew Speed	6,000 RPM maximum
Shaft Loading Max	Axial 10 lbs., (4.54 Kg), Radial 10 lbs. (4.54 Kg)
Shaft Rotation	Bi-directional and continuous
Moment of Inertia	4.0 x 10 ⁻⁵ oz.-in-sec ² (3.0 gm-cm ²)
Starting Torque	0.2 oz.-in.
Weight	4.0 ozs
Cable Seal	Liquid tight, nickel plated brass, NEMA 4X & 6/IP65 Rating
Cable	24 gauge, shielded, UL & CSA certified 24 inch standard or specify cable length

ORDERING INFORMATION

SM16 - 1000 - 5 0 / 5 - 03 - XXX

A B C D E F G

- A. Encoder Series:
- B. Resolution: (Up to 2500 CPR, many standards, please inquire)
- C. Output Configuration:
 - 20 = Single Channel
 - 30 = Single Channel with Index Pulse
 - 40 = Dual Channel
 - 50 = Dual Channel with Index Pulse
- D. Type of Output: 0 = Squarewave
- E. Power Input:
- F. Output Option: 03 = Differential line driver option
- G. Special Deviation:

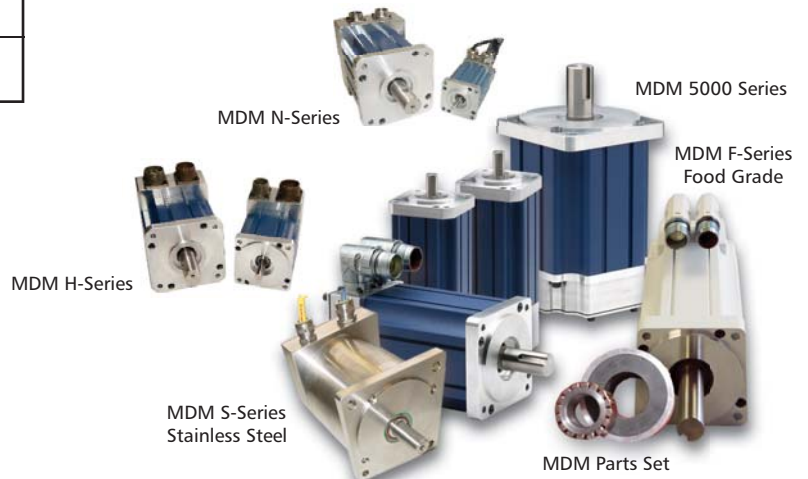

Cleveland Motion Controls

7550 Hub Parkway • Cleveland, OH 44125
 Tel: 216.524.8800 or 800.321.8072
 Fax: 216.642.2199
 cmcsales@itt.com
 www.cmcontrols.com