

INSTRUCTION MANUAL

(MAN-13261)

FOR

DIN RAIL AMPLIFIER

MWI-13261 ULTRA SERIES

ISOLATED



REVISION

BA

Industrial Products Division

REVISION HISTORY

Rev	ECO	Author	Date	Description of Change
AA	XXX	DJM	31 Mar 04	As Released
BA	CLE2912	DJM	01 Aug 04	Updated Block diagram, 4-20mA section, Replaced Transducer Wiring Diagram, Added Damped mA with Scaling Board diagram.

TABLE OF CONTENTS

1	PRODUCT OVERVIEW.....	5
1.1	GENERAL DESCRIPTION	5
1.1.1	CE EMC Responsibility	6
1.2	GENERAL SPECIFICATIONS.....	7
1.3	PHYSICAL SPECIFICATIONS	7
1.4	ENVIRONMENTAL REQUIREMENTS	8
1.5	OPERATING CONDITIONS	8
1.6	EMC TECHNICAL RATINGS.....	8
1.7	EMISSION SPECIFICATIONS.....	8
2	SETUP AND CONFIGURATION.....	10
2.1	LOAD CELL (TRANSDUCER) TERMINALS.....	10
2.2	POWER SUPPLY TERMINALS	10
2.3	OUTPUT TERMINALS	10
2.4	RECOGNITION DIAGRAMS.....	11
2.5	CONFIGURING THE SWITCH SETTINGS	12
2.6	POTENTIOMETERS	13
2.7	EXCITATION VOLTAGE SELECT	13
2.8	CHANNEL SELECT.....	13
2.9	GAIN SELECT SWITCHES.....	14
2.10	METER VOLTAGE/CURRENT CONFIGURATION.....	14
2.11	METER OUTPUT DAMPING SELECT.....	14
2.12	WIRING	15
2.12.1	Wiring termination	15
2.12.2	Transducer Wiring.....	15
2.13	THE POWER SUPPLY	16
2.13.1	Power Wiring diagram	16
2.13.2	Output wiring	16
3	POWER-UP AND TESTING	20
3.1.1	Before Applying Power.....	20
3.1.2	Power Application.....	21
3.2	TRANSDUCER POLARITY CHECK.....	21
3.3	CALIBRATION.....	21
3.3.1	Safety Considerations	22
3.3.2	Checking Transducer Mounting	22
3.4	ACCURACY CONSIDERATIONS	22
3.5	PROPER PRACTICES FOR APPLYING CALIBRATION FORCES.....	24
3.6	APPLYING FORCE TO TRANSDUCERS.....	25
3.7	ADJUSTMENT TOOLS.....	25
3.8	ADJUSTING AMPLIFIER COARSE ZERO	26
3.9	ADJUSTING THE LCH-RCH BALANCE.....	26
3.10	GAIN AND FINE ZERO CALIBRATION	27
3.11	EMC CONNECTIONS AND INSTALLATION.....	28
APPENDIX A. MANUFACTURERS DECLARATION OF CONFORMITY		29
APPENDIX B. CABLE GLANDS		30

WARRANTY

Cleveland Motion Controls warrants the goods against defects in design, materials and workmanship for the period of 12 months from the date of delivery on the terms detailed in the Cleveland Motion Controls, Inc. Terms and Conditions of Sale, document number AO-90131.

Cleveland Motion Controls, Inc. reserves the right to change the content and product specification without notice.

© 2004 in this document is reserved to:
Cleveland Motion Controls, Inc.
7550 Hub Parkway
Cleveland, OH 44125
216-524-8800 Phone
216-642-2199 Fax

INTENDED USERS

This Instruction Manual is to be made available to all persons who are required to configure, install or service the amplifier equipment described in this manual or any other related activity.

FURTHER INFORMATION

For the latest product information, technical literature etc., visit our website at www.cmcontrols.com

ATTENTION: The following information is provided merely as a guide for proper installation. Cleveland Motion Controls cannot assume responsibility for the compliance (or failure to comply) to any code (national, local or other) that prescribes the proper installation of this electronic device or associated equipment. A hazard of personal injury and/or property damage can exist if applicable codes are not adhered to.

1 PRODUCT OVERVIEW

1.1 GENERAL DESCRIPTION

The Ultra Series DIN Rail amplifier (Isolated) provides a complete signal conditioning solution for amplifying and reporting signals from a pair of strain gage-based load cells. Either semiconductor or foil-based load cells can be used and the Ultra Series Isolated DIN Rail amplifier offers an added benefit of an isolation amplifier stage to provide galvanic isolation.



Because the output stage is free to float, be aware of voltage differences on the output side of the amplifier with respect to protective earth ground.

The isolated Ultra Series DIN Rail amplifier has a separate ground reference (common) for the output signals. The ground used by the output circuits is electrically separate from the ground reference for the combined 24V supply and strain-gage signal conditioning.

The Ultra Series DIN Rail amplifier uses a dedicated Instrumentation Amplifier (IA) for each transducer channel. The IA stage amplifies the millivolt level signals generated by the load cells, while effectively rejecting common-mode noise. A wide range of switch selectable gains can be used to provide the most appropriate level of initial amplification. Low drift Surface Mount Technology (SMT) components, Multi-layer Printed Circuit Boards (PCB) and optimum circuit topologies are incorporated to promote load cell signal integrity.

A summing amplifier stage combines the left and right IA channels. The gain of this stage is adjustable over a 10:1 range to allow span calibration of the analog outputs. To improve rejection of “out of band” signals, the summing stage is followed by a DC accurate 2-pole active filter.

A precision voltage source is provided for exciting the strain gage elements in the inter-connected load cells (tension transducers). The circuit includes a short circuit current limit feature to protect the amplifier in the event of mis-wiring. Output voltage is selectable to either of the following:

- 5.0 VDC
- 10.0 VDC

The use of galvanic isolation can aid in reducing noise pickup caused by ground loops in the field wiring and accommodates limited voltage gradients between input and output sections of the application wiring.

The output circuits (+/- 10 volt, 4-20mA and the meter outputs) are galvanically isolated with respect to the combined 24VDC supply terminals and the load cell interface circuits. The isolation is accomplished by using a servo-stabilized linear opto-isolator stage. The output circuitry is powered by an isolated DC to DC converter.

The final analog tension signal is available in a variety of forms. The un-damped output signal can be provided from a +/-10V analog buffer stage, as well as a standard 4-20 mA current loop stage. The voltage supply for the current loop bias is internally provided. The current loop scaling has been specially designed so that minor negative excursions of the tension signal can continue to be reported as currents below 4 mA.

A damped (low pass filtered) version of the tension signal is available for driving displays or recording devices. The damping is switch selectable for a cutoff frequency of either 0.3 Hz or 3.7 Hz. Damping is useful for improving the readability, effectively masking higher frequency fluctuations superimposed on the tension signal. This damped output stage can be configured to be either:

- +/- 2V analog output - intended primarily for driving Digital Panel Meters (DPM).
- +/-1 mA current source - when configured as the current source, the 1 mA output is typically used to drive D'Arsonval style analog meters.

1.1.1 CE EMC RESPONSIBILITY

Cleveland Motion Controls DIN Rail Amplifier MWI-13261 Ultra Series module can be considered a component performing a direct function and therefore is subject to the provisions of the EMC Directive.

The Cleveland Motion Controls DIN Rail Amplifier MWI-13261 module may be used by a manufacturer as a component of a larger system, along with other components, which may or may not bear the CE mark. The system assembler is responsible for the compliance of the system as a whole with the EMC Directive.

To assist manufacturers, suppliers, and installers of relevant apparatus, the Cleveland Motion Controls DIN Rail Amplifier MWI-13261 module is compliant to EN61326:1997 when installed according to these instructions. Manufacturers, suppliers, and installers of relevant apparatus may use this compliance as a contributing basis for their own justification of overall compliance with the EMC Directive.

Before installing the Ultra Series DIN Rail Amplifier you must clearly understand who is legally responsible for conformance with the EMC Directive. Misappropriation of the CE mark is a criminal offense.

1.2 GENERAL SPECIFICATIONS

Item	Specification	Comments
Input Supply		
Power Supply Requirements	24 VDC @ 180 milliamps	Basic Isolated Amplifier
Power Supply Limits	20 to 28 VDC	Basic Isolated Amplifier
Load Cell (Transducer)		
Transducer Excitation (Vexc)	5.0 or 10.0 VDC	Shipped with V EXC. Set at 5.0 VDC. 100milliAmp maximum. Switchable to 10 VDC with internal switch.
Transducer Resistance Range	100 to 1000 Ohms	Do not exceed maximum excitation current.
Transducer Gage Types	Semi-Conductor (20-100 mV/V) or Foil (2-3 mV/V)	Gain switches configure each input gain from 5 to 620 as needed, to amplify transducer voltage.
Amplifier		
Input Impedance	10K (Line-Line) Nominal	Inputs may be used single ended or together as a differential pair
Selectable Gains, IA stage	5, 25, 125, 620	Gains switched by referring to section 2.5 in this document.
Calibration Range, summing stage	Min. 0.9 - Max. 9	Multi-turn Gain adjustment provided.
Zero Range	+/- Full Scale Output	Coarse adjustments for each channel provided. Fine adjustment affects sum.
Nominal Input Signal Levels	0-500 millivolts 0-20 millivolts	Each semi-conductor load cell Each foil-gage load cell
Pulse Response	10-90% Step, 0-10V and 4-20 mA	300 milliseconds for undamped signals
Amplifier Output Signal	+/-10 VDC @ 2 mA 4-20 mA current loop 0-2 VDC @ 2 mA +/- 1milliAmp into ≤ 8 KOhms	+/-10 is undamped signal Current loop undamp +/- 2VDC signal (or 1mA) has switch selectable damping (0.3 or 3.7 Hz)
Isolation		
Isolation Stage	150 VRMS	output circuit potential not to exceed 150 VRMS from protective earth potential

1.3 PHYSICAL SPECIFICATIONS

Item	Specification	Comments
Enclosure Type	DIN Rail mountable with main user adjustments accessible from front surface. Snap-on cover to access configuration switches and setup potentiometers.	Phoenix EG type ABS enclosure. Color green.
Enclosure Size	Base: 45 mm wide by 75 mm high Depth: 105 mm	1.8 inches (width) by 3.0 inches (height) 4.2 inches (depth)
Weight – Basic Amplifier	170 Grams	6 ounces
Terminals	Two removable plugs of eight terminals each, keyed to avoid mis-plugging	Screw type terminals, will accept up to one 12 AWG or equivalent. Phoenix "Combicon" type.

1.4 ENVIRONMENTAL REQUIREMENTS

Requirement	Description
Enclosure	IP20 NEMA 1
Operating temperature	0 to 55 degrees C 32 to 132 degrees F
Humidity	Non-condensing 85% at 55 degrees C 85% at 132 degrees F
Altitude	1000 meters 3300 feet
Atmosphere	Non-flammable, non-corrosive and dust free
Storage temperature range	-25 to 80 degrees C -13 to 176 degrees F
Transport temperature range	-25 to 80 degrees C -13 to 176 degrees F

1.5 OPERATING CONDITIONS

Condition	Ultra Series DIN Rail amplifier
Installation category	Category III
Pollution	Pollution Degree 2
Input supply	Earth (Ground) referenced
Protection	Enclosure mounted

1.6 EMC TECHNICAL RATINGS

Port	Phenomenon	Test Standard	Level	Test Standard
Enclosure	ESD	EN 61000-4-2:	8KV AD, 1KV CD	EN 61326:1997
Enclosure	RF Field	EN 61000-4-3	10V/m, 1 Khz AM	EN 61326:1997
Transducer Leads	Fast Transient Burst	EN 61000-4-4	1kV	EN 61326:1997
Output Leads	Fast Transient Burst	EN 61000-4-4	1kV	EN 61326:1997
Transducer Leads	Conducted Immunity	EN 61000-4-6	3V/m	EN 61326:1997
Output Leads	Conducted Immunity	EN 61000-4-6	3V/m	EN 61326:1997
*AC Power Line	Surge	EN 61000-4-5	+/-2KV L to PE +/-1KV L to L	EN 61326:1997
*AC Power Line	Voltage Dips	EN 61000-4-11	+/-0.5 Cycle 100%	EN 61326:1997

*These specifications apply when using CMC power supply, MWI-13418.

1.7 EMISSION SPECIFICATIONS

Port	Phenomenon	Test Standard	Level	Generic Standard
Enclosure	Radiated	EN 61326: 1997	Class A	EN 61326:1997



The levels of performance indicated are achieved when the Ultra Series DIN Rail Amplifier is installed by using the instructions and specifications outlined in this document.

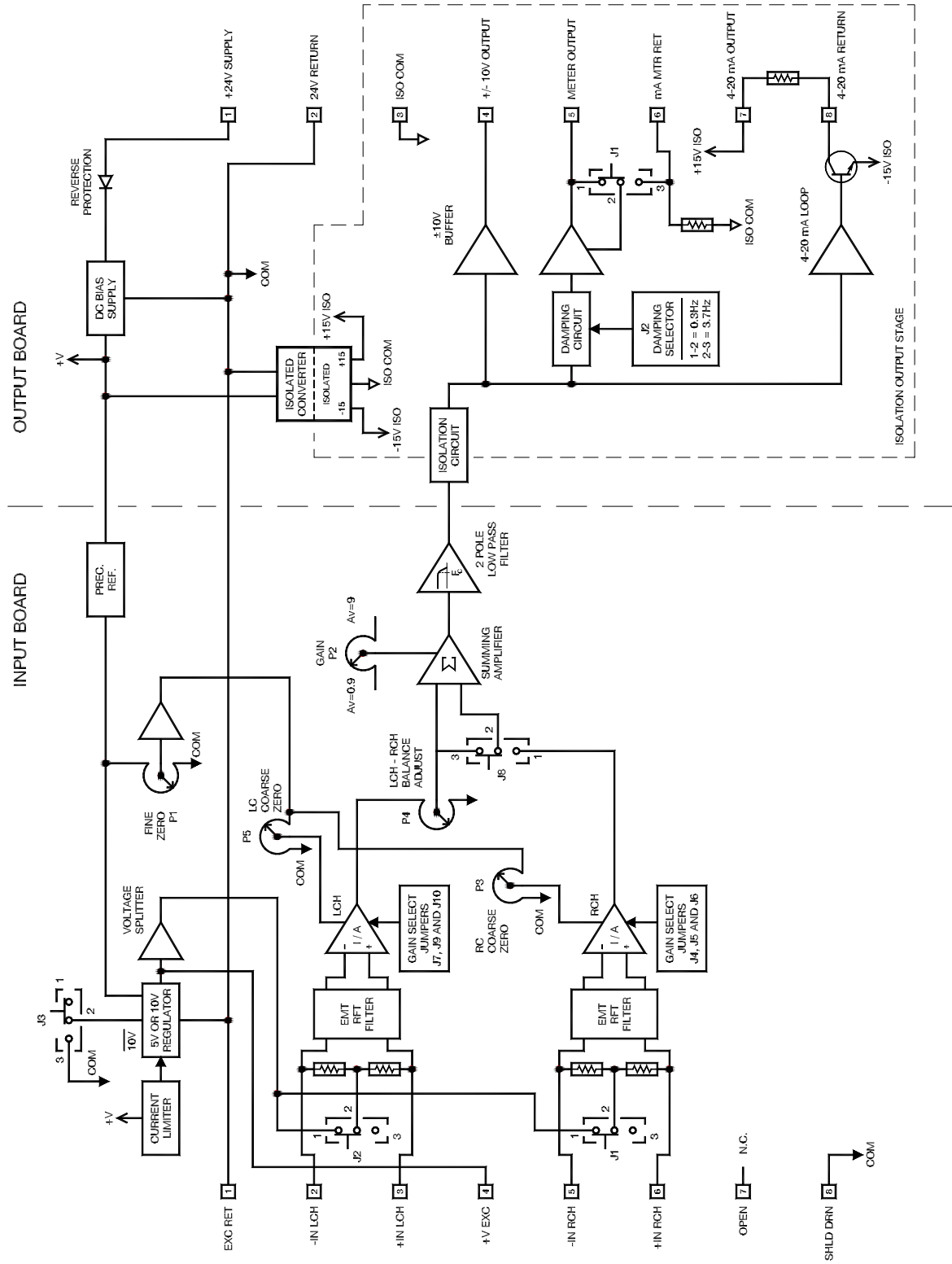

Figure 1 Block Diagram of Ultra Series DIN RAIL MWI -13261

2 SETUP AND CONFIGURATION

2.1 LOAD CELL (TRANSDUCER) TERMINALS

Supply	Terminal	Function	Description	Notes
J1-1	EXC RET	Supply return for bridge excitation	Zero voltage terminal for LCH and RCH transducers	COMMON
J1-4	+V EXC	Bridge excitation source for LCH and RCH transducers	5.0 Volt or 10.0 Volt supply terminal,	max. load 100 mA
J1-2	-IN LCH	Load cell signal from LCH transducer	Low going output from LCH transducer	10K ohm line-to-line
J1-3	+IN LCH	Load cell signal from LCH transducer	High going output from LCH transducer	
J1-5	-IN RCH	Load cell signal from RCH transducer	LOW going output from RCH transducer	10K ohm line-to-line
J1-6	+IN RCH	Load cell signal from RCH transducer	High going output from RCH transducer	
J1-7	OPEN (N.C.)	NO CONNECTION		Make no connection
J1-8	SHLD DRN	Cable shield drain terminal	Cable Shield for LCH and RCH transducer cables	Connect only at amplifier



Transducers (load cells) use strain gages which have limited insulation levels to ground (earth). This requires that the COM terminals be connected to ground (earth) to prevent damage to the transducers (load cells).

2.2 POWER SUPPLY TERMINALS

Supply	Terminal	Function	Description	Notes
J2-1	24V RET	Power Supply	Power supply return	Must not exceed 50 volts from P.E.
J2-2	+24 VDC	Power Supply	Positive supply source	+20 to +28 VDC @ 180 mA max



A fuse with a rating of 0.38A must be used in the 24 VDC supply lead to limit potential damage to the amplifier in the event of circuit malfunction.

2.3 OUTPUT TERMINALS

Output	Terminal	Function	Description	Notes
J2-3	COMMON	Output signal return		Common for +/- 10V and +/- 2V output
J2-4	+/- 10V OUT	Voltage Output signal	Undamped bi-polar tension signal	max. load 2 mA
J2-5	mA MTR RET	mA meter signal	Used for current format meter return	Current through 1 mA meter returns here
J2-6	METER OUT	Output signal	Damped bi-polar tension signal	Switchable 2.0 V F.S. or 1 mA F.S.
J2-7	4-20mA OUT	Current loop Output signal	Undamped tension signal, current loop source	Internal Loop supply
J2-8	4-20mA RET	Output current signal	Current return for 4-20 mA loop	At -15 VDC with respect to common

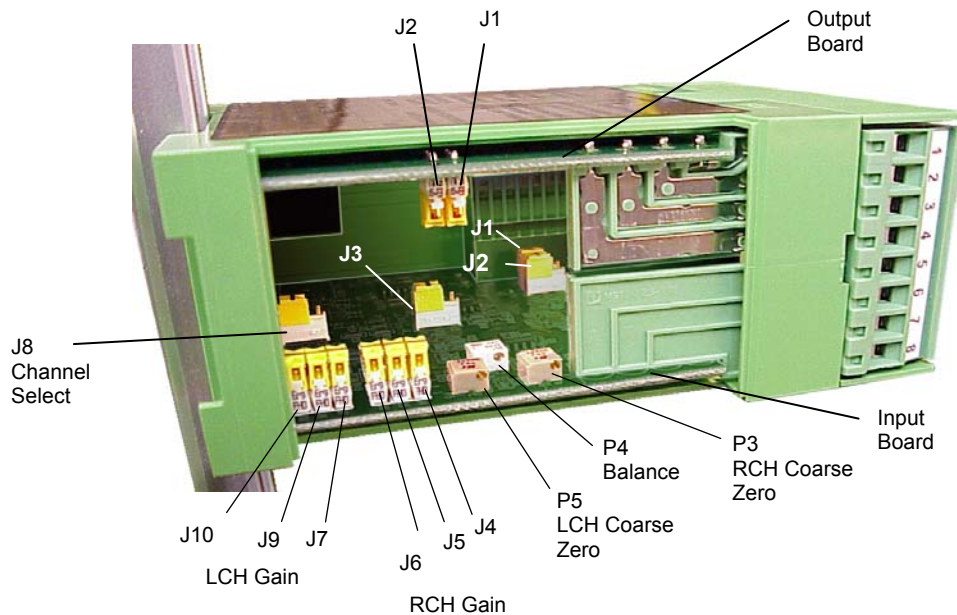

Figure 4 - Internal Jumper-switches and Potentiometer Location

2.5 CONFIGURING THE SWITCH SETTINGS

A number of operational characteristics can be configured prior to mounting or wiring the amplifier. We recommend that you first familiarize yourself with the internal switch locations, settings, and potentiometers by opening the snap-on access cover. Figure 4 illustrates the location of configurable items on each of the printed circuit boards.



Use an approved anti-static wrist strap when adjusting any switch setting or potentiometers on the amplifier.

Switch	PCB Location	Function
J3	Input	Configures Excitation voltage for 5.0 or 10.0 VDC. The amplifier is factory set at (setting 1-2) for 5.0V
J8	Input	Selects left channel only (setting 2-3) or LCH + RCH (setting 1-2) as input to summing amplifier stage. Slide the jumper switch to (1-2) for normal operation with two transducers. Refer to setup/calibration section for more information.
J1	Input	Connects completion resistances of RCH transducer input to 1/2 of excitation voltage (setting 1-2). Slide the jumper switch to setting (2-3) for normal operation with Ultra Full-Bridge transducers. Slide jumper switch to setting (1-2) if the channel is unused.
J2	Input	Connects Completion resistances of LCH transducer input to 1/2 of excitation voltage (setting 1-2). Slide the jumper switch to setting (2-3) for normal operation with Ultra Full-Bridge. Slide the jumper switch to setting (1-2) if the channel is unused.
J10 J9 J7	Input	Sets voltage gain of LCH Instrumentation amplifier to 5, 25, 125 or 620. The jumper switches are factory set to (1-2) for minimum gain (Av = 5). Refer to section 2.9 for more information on setting Gain select switches.
J6 J5 J4	Input	Sets the fixed gain of RCH Instrumentation amplifier. The jumper switches are factory set to (1-2) for minimum gain (Av=8).
J1	Output	Configures meter output stage for +/- 2V F.S. or +/- 1 mA F.S. The jumper switch is factory set to (1-2) for voltage output. Voltage and current modes use different terminals.
J2	Output	Selects meter damping 0.3 Hz or 3.7 Hz. The jumper switch is set to (2-3) for minimum damping. (3.7 Hz)

2.6 POTENTIOMETERS

In addition to the Gain and Zero adjustable potentiometers visible on the front of the unit, there are adjustments you can make by removing the snap-off cover on the side of the amplifier. The adjustments are on the output and input printed circuit boards as shown in Figure 4. The following table provides you with a list of potentiometers, where they are located on the Ultra Series DIN Rail input printed circuit board, and a description of their functions. For information on the correct adjustment tools to use, refer to section 3.7 in this document.

Potentiometer	Reference Designator	Location	Function
GAIN	P2	Unit Front	Provides 10:1 “vernier” adjustment of the summing amplifier. It is a multi-turn potentiometer, with clockwise rotation causing an increase in amplifier gain. When turned fully counter clockwise, the potentiometer will cause the summing amplifier stage to provide the minimum gain of 0.9.
ZERO	P1	Unit Front	Provides a fine zero (offset) adjustment. It simultaneously and equally affects both of the instrumentation amplifiers. It is a multi-turn potentiometer, with clockwise rotation causing a positive shift in the analog outputs. It should be set mid-way prior to setting the COARSE ZERO adjustment.
LCH Coarse Zero	P5	Input, behind access cover	Establishes the coarse zero of the Left Channel (LCH) instrumentation amplifier. Because of the ability to cause +/- Full scale (+/- F.S.) output shifts, it is important to correctly follow the final set-up and calibration procedure so that premature amplifier “clipping” is avoided
RCH Coarse Zero	P3	Input PCB, behind access cover	Establishes the coarse zero of the Right Channel (RCH) instrumentation amplifier. Because of the ability to cause +/- Full scale (+/- F.S.) output shifts, it is important to correctly follow the final set-up and calibration procedure so that premature amplifier “clipping” is avoided. This is a multi-turn adjustment potentiometer.
LCH-RCH Balance	P4	Input PCB, behind access cover	Allows for matching (balancing) the gain between transducers if needed. Don't adjust this unnecessarily; it has been factory set for equal balance. Turning clockwise boosts the signal for the Left Channel. This multi-turn adjustment potentiometer has been deliberately “set back” from the adjacent ZERO potentiometers to discourage accidental adjustment.

2.7 EXCITATION VOLTAGE SELECT

The Excitation Voltage is determined by the position of jumper switch J3. Refer to Figure 4 for jumper-switch locations. The jumper default setting is J3 (1-2) position for 5.00V excitation. Do not use 10V setting J3 (2-3) position unless explicitly permitted by the load cell electrical specifications. Promptly verify the excitation voltage after power-up to avoid overdriving strain gages. Note that if there is no external load resistance, the voltage may rise to 6.4V, but will immediately regulate at 5.00V when the load cells are connected.

Keep in mind that the strain gage based load cells can readily operate at less than rated voltage (with a corresponding reduction in output signal). This fact is helpful in the event that a “10 V “ load cell exhibits an output signal that is excessive for even the lowest amplifier gain.

2.8 CHANNEL SELECT

Jumper-switch J8 configures the inputs to the Variable Gain Summing Amplifier stage. For most applications involving a pair of transducers, it is placed in the J8 (1-2) position so that the analog outputs represent the *sum* of the left and right channels (LCH + RCH). During portions of the calibration procedure, or if only the left transducer channel is utilized, it is placed in the J8 (2-3) position. In this position, the signals at the analog outputs represent only the left channel (LCH).

2.9 GAIN SELECT SWITCHES

The group of jumper-switches that control the fixed gain of the Instrumentation Amplifiers (IA) are located close to the front left edge of the Input card. (Refer to Figure 4) Typically, you configure both channels to the same setting if both transducers are the same force rating.

When the amplifier is held horizontally with the pluggable connectors facing toward the right (refer to Figure 4), the leftmost cluster of jumper switches, (J10, J9, J7) sets the gain for the LCH (Left Channel) Instrumentation Amplifier. Similarly, the right cluster of jumper switches, (J6, J5 and J4) sets the gain for the RCH (Right Channel) Instrumentation Amplifier. The lowest gain ($A_v = 8$) occurs when all of the switches are in the 1-2 position. As switches are moved “away” (into position 2-3) from left to right, the gain progressively increases as described in following table:

Left Channel			Voltage Gain	Right Channel		
J10	J9	J7		J6	J5	J4
1-2	1-2	1-2	5	1-2	1-2	1-2
2-3	1-2	1-2	25	2-3	1-2	1-2
2-3	2-3	1-2	125	2-3	2-3	1-2
2-3	2-3	2-3	620	2-3	2-3	2-3



When changing the internal jumper-switch settings, it is always advisable to change the settings with the 24 VDC power removed. If this is not possible, it becomes particularly important to use a non-conductive tool to alter switch positions.



Make sure that jumper-switch settings are fully in position to avoid accidentally leaving a switch in an “in-between” state.



The total gain range of the amplifier is the product of the IA and summing amplifier gains (variable).

Using the lowest gain switch settings, the net gain is $5 \times (.9 \text{ to } 9.0)$ or 4.5 to 45

With the other gain combinations available, a 10 volt output can be produced with input voltages ranging from between 0.002 to 0.50 volts.

2.10 METER VOLTAGE/CURRENT CONFIGURATION

The damped output for a tension indicator can be configured as either a +/- 2V output or a +/- 1mA output by changing the position of jumper-switch J1 located on the Output Card (Refer to Figure 4 for location). Voltage output is selected by setting J2 to the (1-2) position. Current output is selected when J2 is set to the (2-3) position. Note that different wiring terminals are employed for the signal return when configured for current or voltage.

2.11 METER OUTPUT DAMPING SELECT

The amount of damping for the meter output (intended to drive a tension indicator) can be configured by the position of jumper-switch J2 on the Output card (refer to Figure 4 for location information). Setting the jumper switch to J2 (1-2) sets the break frequency at 0.3 Hz. Setting the jumper switch to J2 (2-3), the break frequency setting is raised to 3.7 Hz

2.12 WIRING

Most start-up problems are the result of mis-wiring or failure to reference the detailed information in this manual. While a convenient basic wiring diagram can be found printed on the side label of the amplifier case, the diagram is intended only as a helpful guide when checking field wiring. Additional information details can be found in the subsequent sections of this manual and should be referenced before actual installation begins.

2.12.1 WIRING TERMINATION

Terminal(s)	Conductor Size	Insulation Strip Length	Torque	Notes
All	1.5mm ² /16 AWG	7 mm (0.28")	0.5 Nm / 4.4 lb.-in.	One wire this size per terminal
	0.75mm ² /18 AWG	7 mm (0.28")	0.5 Nm / 4.4 lb.-in.	Up to two wires this size per terminal
	0.5mm ² /20 AWG	7 mm (0.28")	0.5 Nm / 4.4 lb.-in.	Up to two wires this size per terminal

2.12.2 TRANSDUCER WIRING

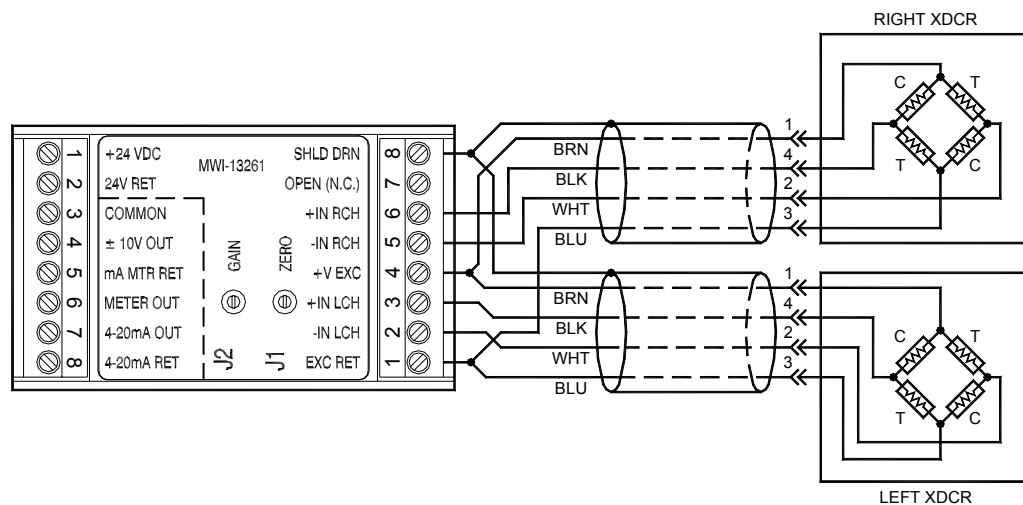

Figure 5 - Full-bridge Transducer Wiring

The successful amplification of low level signals from strain gage transducers requires particular attention to wiring practices to avoid signal degradation in the industrial environment. Degradation can result from AC noise pickup and/or DC errors. Refer to the following guidelines to identify measures that may help retain signal quality:

- Use Ultra Series shielded transducer cables to reduce pickup of noise through electrostatic coupling.
- Route cables away from sources of electrical interference (motor wiring, contactors, etc).
- Connect the shield drain wire at one end only to discourage shield currents.
- Optimum high frequency grounding requires low inductance connections that are enhanced with short conductors or planar ground conductors (wide ground braids).
- Do not pre-tin the stranded wires inserted into the pluggable connector.
- A stable connection relies on the springy nature of stranded conductors to ensure a low contact resistance despite thermal cycling and airborne impurities.
- Avoid temperature extremes or gradients where electrical connections are made between different metals. Connections can cause thermocouple voltages to be generated, which then become superimposed on transducer signals.
- In severe cases, additional shielding may be required in the form of either external flexible braided shields or running the field wiring wires inside metallic conduit.

2.13 THE POWER SUPPLY

For best performance a regulated power supply should be used with the Ultra Series DIN Rail amplifier. It is important that you pay particular attention to the power supply for susceptibility to the effects of conducted and radiated energy from noise sources. Every effort should be made to provide stable voltage to the amplifier using correct wiring practices and filters. To protect against circuit damage, include a 0.38 Amp fuse in the power supply output lead to each amplifier in case of amplifier or power supply malfunction.

2.13.1 POWER WIRING DIAGRAM

The 0.38 A fuse in the +24VDC power lead is required for protection of the amplifier in the event of amplifier or power supply malfunction.

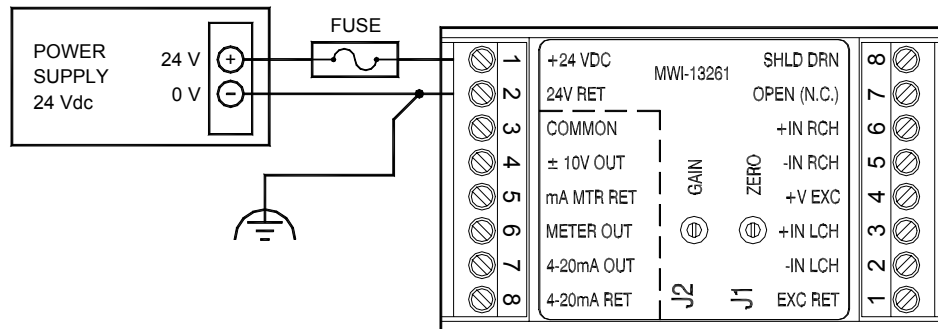

Figure 6 - Wiring diagram for use with 24 VDC power supply



The power source for the power supply shall be fused at the proper rating to prevent over current in the supply leads due to a power supply failure.

2.13.2 OUTPUT WIRING

The load in this connection may be an indicator, recorder, data acquisition device or the analog input terminals of a control device such as a DC drive or a programmable logic controller. The output signal at this terminal is undamped and is the output terminal that provides that fastest response to changes in the transducer (load-cell) load. Note that the cable’s shield drain wire should be connected at only one end, preferably at the “receiving end”.

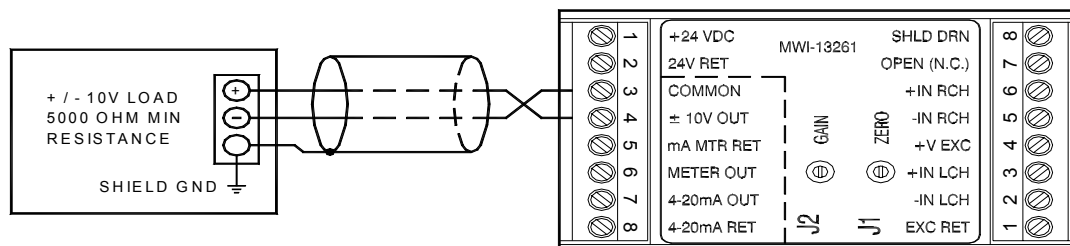

Figure 7 - Output Wiring, +/- 10V Analog

2.13.2.1 4 TO 20 MA ANALOG CURRENT LOOP

The 4-20 mA current loop output is undamped and can be used concurrently with the other outputs. The 20 mA current level corresponds to the +10V output. The 4 mA level corresponds to 0 volts on the 10V output.

This output does not have an individual Gain and Zero potentiometer adjustment. If multiple types of analog output are being used, a compromise must be made during calibration, or a particular output must be favored (over one that can best accommodate individual external scaling and offsetting).

The bias supply to drive the current loop is provided internally by the Ultra amplifier. External burden resistance (loop resistance) can range between 50 and 750 ohms.



The circuitry which drives the current loop is essentially a linear regulator stage. This means that internal power dissipation (hence temperature rise) is lessened when higher values of external burden resistance are used. Moderate values of burden resistance can be strategically employed to minimize internal temperature rise (and thereby minimize amplifier drift in sensitive applications).

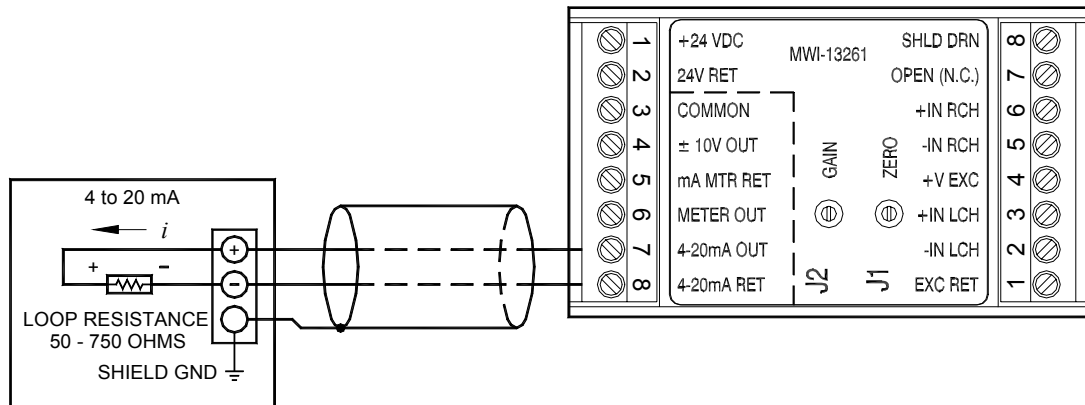

Figure 8 - Output Wiring, 4 to 20 mA Analog Current Loop, Floating Burden

2.13.2.2 APPLICATION INTERFACE DETAILS

The 4-20 mA output stage is designed to drive a loop current through a floating burden resistance. Examples of driving a loop current through a floating burden resistance include: a loop powered 4-20 mA display or, the isolated input of receiving electronics (isolated Analog to Digital input). The 4-20 mA output can also drive non-isolated (or ground referred) burden resistances provided that the circuit that employs the burden *does not* connect to the isolated common (COM, J2-3) of the amplifier.

For a better understanding as to why the burden must be floating with respect to the amplifier's isolated common (COM, J2-3) refer to Figure 9. This figure illustrates that the 4-20 mA OUT (J2-7) is connected to the +15V internal supply voltage and the 4-20mA RET terminal sinks loop current toward the -15V internal supply. A truly floating burden receives the loop current that is controlled by the amount of current sinking into the -15V supply. The current is supplied by the +15V supply. Incorrectly connecting burden resistance between the 4-20mA OUT and COM (J2-3) would cause excessive current to flow. Incorrectly connecting the 4-20mA RET (J2-8) to COM (J2-3) results in the 4-20mA current being drawn from ground and bypassing the burden resistance.

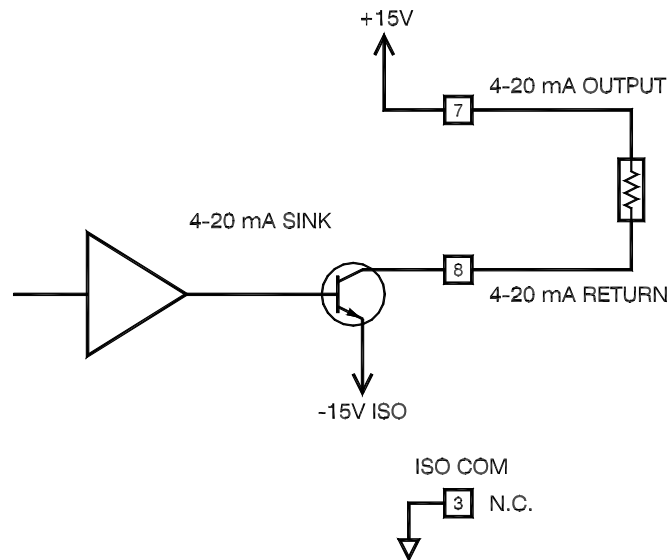

Figure 9 – 4-20 mA Output Circuit Wired for Floating Burden

While possible to interface the 4-20 mA current loop into circuits which do exhibit resistances between their burden and the amplifier isolated COM, (Refer to Figure XX.), this is a less desirable configuration. If you chose to wire the amplifier in this way, you must keep the following in mind. When the commons of both circuits are connected, be sure that the amplifier's 4-20 mA OUT remains unconnected and that the 4-20 mA RET (J2-8) is connected to draw loop current from a ground referred burden resistance at the receiving circuit. The burden resistance must not exceed 250 Ohms due to the reduced bias voltage, however a full-scale signal of -5.0 VDC is still possible ($-5V = -20\text{ mA} \times 250\text{ Ohms}$).

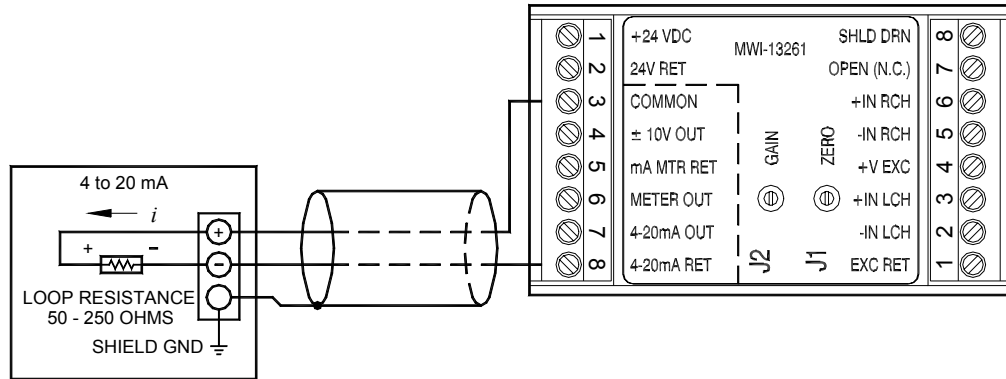

Figure 10 – 4-20 mA Output Wiring for Ground Referred Burden

2.13.2.3 DIGITAL VOLTMETER

The +/- output terminal is designed to provide +2.0 volts when the +/- 10 V output terminal is adjusted (with the Gain and Zero pots) to be +10.0 volts (this is full scale). To achieve different scaling, adjust gains on the Digital Panel meter (DPM).

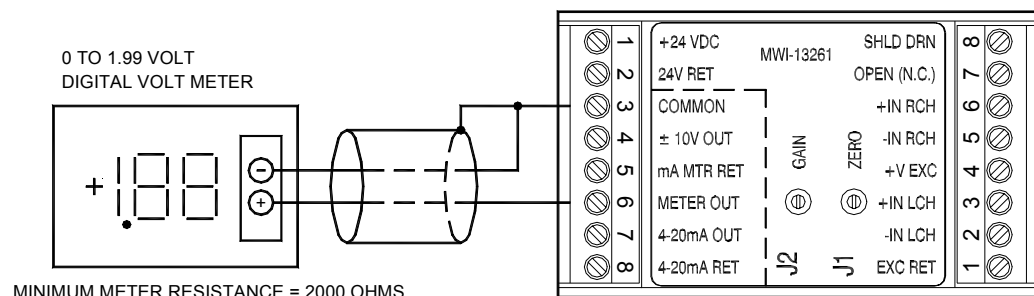

Figure 11 - Output Wiring, Damped +/- 2V Analog

2.13.2.4 DAMPED +/- 1 MA ANALOG

The meter output stage can be configured to operate as current output (sinking or sourcing current depending upon output polarity). It can be used concurrently with the other outputs. It does not have an individual Gain and Zero adjustment, necessitating that a compromise be made during calibration, or a particular output be favored (over one that can accommodate external scaling and offsetting).



To facilitate individual scaling of the analog meter a panel meter (MO-13655) with scaling board, is available as an accessory for use with Ultra Series tension transducer amplifiers. The scaling board lets the analog meter have a different scaling factor than that of the main (un-damped) analog output.

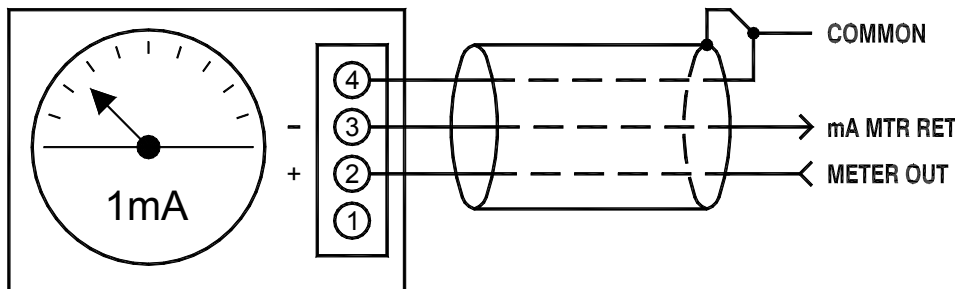

MAXIMUM METER RESISTANCE = 7K OHMS

Figure 12 - Output Wiring, Damped mA Analog Meter with Scaling Board

3 POWER-UP AND TESTING

3.1.1 BEFORE APPLYING POWER

Before applying power, check the wiring to the amplifier. Pay particular attention to the following:



- Double check the transducer connections to ensure that the excitation supply is not short-circuited.
- Use an approved anti-static wrist strap when adjusting any switch settings/potentiometers on the amplifier.
- Use the appropriate tool when making any adjustments to the potentiometers on the amplifier or changing switch settings. Damage to the circuitry may occur if excessive force is used or a conductive tool accidentally contacts internal voltages.

Before applying power, confirm that the Zero potentiometers are mid-span and the Gain potentiometer is minimum. Use the following table to adjust potentiometers:

Adjustment Potentiometer	Default
Gain – P2	Full counter-clockwise
Zero – P1	Mid-way (9 turns from full counter-clockwise)
LCH – coarse zero	Mid-way (6 turns from full counter-clockwise)
RCH – coarse zero	Mid-way (6 turns from full counter-clockwise)

3.1.2 POWER APPLICATION

Apply DC power to the amplifier and use a DC voltmeter to confirm that the supply polarity and voltage is within the prescribed limits. As soon as is practical, confirm that the excitation voltage is either 5.0 VDC or 10.0 VDC as appropriate for the type of load cells being used. Promptly identifying any over-voltage condition can help minimize potential damage to the strain gage elements internal to the transducer. Note that the excitation voltage may rise to approximately 6.5 VDC if the amplifier is operated without any transducers attached. This voltage will return to the precisely regulated value when the transducer load is connected.

3.2 TRANSDUCER POLARITY CHECK

This step is important in identifying transducer or wiring problems early in the setup procedure. Information learned in this check will be instrumental in setting the optimum gains for the Left and Right Instrumentation Amplifier stages. The following steps described the polarity check only for the Left Channel (LCH), but the steps are applicable to the Right Channel (RCH) as well.

1. Measure the -LCH load cell signal with a digital volt meter (DVM) at the input to the amplifier with respect to the Excitation Return (EXC RET) to confirm that it is roughly 58% of the excitation voltage.

Measure the +LCH signal to confirm that it is roughly 58% of the excitation voltage.

If both measurements are less than 50% of the excitation voltage, then it is likely that the BLU and BRN transducer cable leads have been mis-wired.

2. Measure the voltage at the +LCH input to confirm that it becomes more positive when a small trial force is applied in the transducer's intended force direction. The -LCH input should become less positive when the same force is again applied. If the "sense" of this voltage change is incorrect for the way the transducer is mounted, interchange the load cells wiring for -LCH and +LCH signals.
3. Without a calibration force applied to the load cells, measure the "UNLOADED" DC voltage *difference* between the LCH+ and -LCH signals. Use the lowest practical voltmeter scale to provide a meaningful measurement. Remember or record this measured value for later use.
4. Apply the intended full scale force to the load cell and measure the "LOADED" voltage. Both of these voltages, as well as the difference between these two voltages, help to indicate the best Gain setting configuration at the first amplification stage. Select the highest possible gain for the first stage that does not result in saturation ("clipping") of the transducer signal. If the voltages do not exceed 180mV, then a gain of 25 is appropriate. Similarly, a lower signal of 35mV could use a higher gain of 125.
5. Set the IA gains using the jumper switches (refer to section 2.9). We recommend using the same gain setting for both the LCH and RCH, consistent with the requirement of avoiding saturation.

3.3 CALIBRATION

The following sections describe the calibration process for establishing particular voltages at the +/- 10V analog output. If you intend to use the 4-20 mA output, then make that output the focus of your calibration efforts. Similarly, calibrate to the meter output if that is your primary focus.

3.3.1 SAFETY CONSIDERATIONS

Don't let safety be an afterthought. Before beginning calibration of transducers, review and follow applicable policies and procedures to ensure worker safety. Machinery must be in a safe state, and you should be aware of additional hazards that can arise when calibrating higher force transducers. The following points are important to remember:

- When dead weights are used to produce a force, always wear steel-toed shoes.
- When manually handling weights, use safe lifting practices to avoid injury.
- Size any cordage or straps with an ample safety factor to reduce the chances of failure and falling weights.
- Consider where the cords and weights will travel should a failure occur.
- Check that all hardware is mounted with the appropriate fasteners (thread size and pitch, fastener grade, length of thread engagement).

3.3.2 CHECKING TRANSDUCER MOUNTING

Before preparing to apply force to the transducer(s) and calibrating the amplifier you should check to be sure that the load cell is orientated and mounted in accordance to the transducer installation instructions. Common problems include:

- Failure to orient the transducer on a flat (machined) surface.
- Poor shaft alignment that exceeds allowable limits.
- Excessive or insufficient fastener torque.
- The transducer is not mounted correctly and the axis-sensing is not true to the applied force (bi-sector of the wrap-angle).
- The roll shafts are mounted without allowance for shaft expansion or contraction.
- The transducer is positioned in the web path so that the wrap angle is not constant.

For more information about proper practices for applying calibration, refer to section 3.5 in this document.

3.4 ACCURACY CONSIDERATIONS

The application of an accurate calibration force requires careful attention to minimizing the non-ideal affects of the real world. Keep the following points in mind:

- Allow the transducer and amplifier to reach thermal equilibrium before conducting calibration. Ideally, the temperature should reflect the expected operating conditions.
- The test force should be a moderate percentage of the intended working force of the transducer, and never over the 100% Maximum Working Force (MWF) or, you risk calibrating with an overloaded ("clipped") transducer signal.
- Cycle the load on the transducer a number of times with the test force to pre-condition or "set" the transducer prior to calibration. Repeat this procedure again before calibrating if the transducer has been disturbed (i.e. bolts re-torqued).
- With very low force transducers consider that connecting a test mass involves some finite cord mass.
- Passing a cord over a roll on its way to the transducer inevitably causes some amount of friction. The worst case scenario involves passing the working part of a cord over a roll that doesn't readily freewheel.
- When all else is done correctly, the largest remaining contributor to error is friction. If friction cannot be reduced, consider determining the magnitude of the friction through measurement and then making first order corrections numerically.

- Passing a cord over a roll on its way to the transducer will cause some amount of friction. The worst case scenario is in passing the working part of a cord over a roll that doesn't readily freewheel. A test was conducted to determine the loss on a stationary 4" diameter anodized roll with a 90 degree wrap angle. It exhibited a 25 to 30% loss in force due to friction!
- Always apply and remove the test load in a continuously increasing or decreasing manner, so that the force changes are monotonic. This helps to avoid disturbing any hysteresis component of the transducers force signal.
- When calibrating for a particularly wide roll that will always have a narrower product tracking to one side, consider applying the calibration force at the roll position that represents the center of the product. This will automatically cancel some of the affects of transducer gain imbalance without the need to actually re-balance the transducers gains within the amplifier.
- It is a good practice to verify linear operation of the transducer and amplifier by applying a final test force that falls somewhere between the zero and full-scale endpoints. The intent is not to conduct calibration, but to confirm the hardware's ability to accurately report a measured force.

3.5 PROPER PRACTICES FOR APPLYING CALIBRATION FORCES

Seldom is a transducer oriented such that the calibration can be done by simply hanging a true dead weight from the roll. By generating a tension force that follows the same web path across the roll, you avoid the necessity of making manual (numerical) calculations to correct for the details of different wrap angle, transducer orientation, etc.

The following diagrams show you the correct and incorrect techniques to use when applying calibration forces.

Examples of Inaccurate Wrap Angles

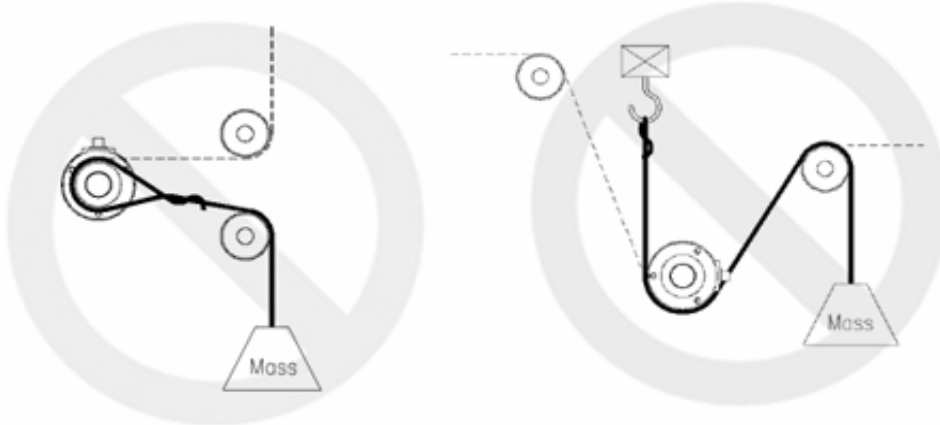

In this example, there was a disregard for maintaining the correct wrap angle. The dotted line indicates the proper web path.

In this example, the true web path was difficult to access and an incorrect path was implemented using a convenient, but incorrect anchor point.

Example of Correct Wrap angles and Anchor Point

In this example, the anchor point and the wrap angle have been correctly determined!

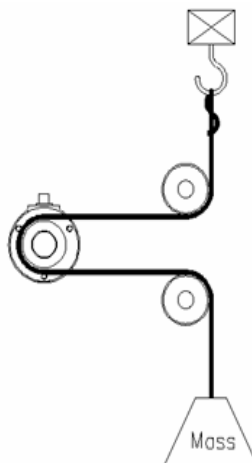

Examples of Force Loss due to Friction at Driven Roll

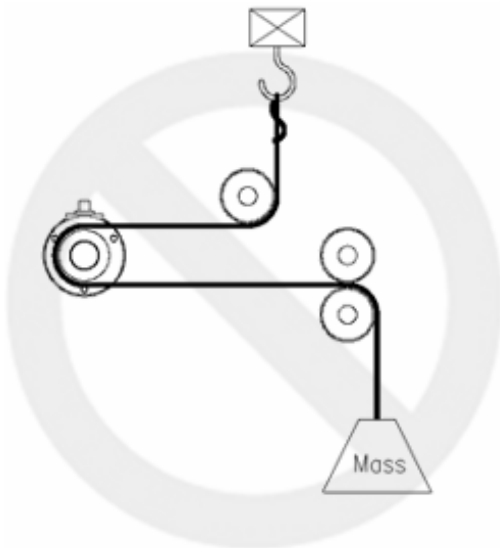

In this example, only a fraction of the test force is transferred to the transducer due to drag from the driven roll.

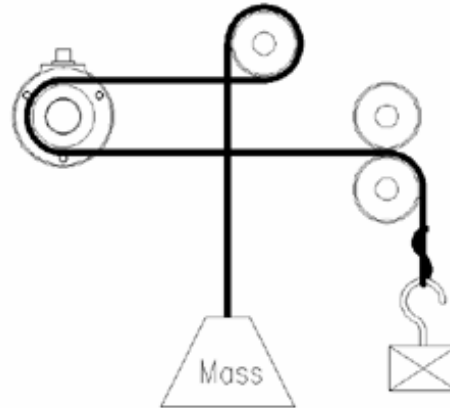

In this example, by rearranging the anchor point and the force location as well as utilizing the idle roll, the frictional losses are minimized.

3.6 APPLYING FORCE TO TRANSDUCERS

The application of an accurate calibration force can be a challenge. Keep the following points in mind:

- Allow the transducer and amplifier to reach thermal equilibrium before conducting calibration. Ideally, the temperature should reflect the expected operating conditions.
- With very low force transducers, consider that connecting a test mass will involve some finite cord mass.



When conducting a calibration that involves a large mass, it is often practical to use a series of smaller masses added in succession. Consider performing an initial Zero and Gain adjustment when the first 20% of the weights have been applied. By performing the calibration using this method, the Zero and Gain adjustments can be made approximately correct earlier in the calibration effort (before many weights have been handled). When the full calibration load is applied, there is a better chance that only minor adjustments will be needed.

3.7 ADJUSTMENT TOOLS

Using the correct tools simplifies the setup process and necessary adjustments. Keep the following points in mind:

- The Ultra Series DIN Rail amplifier utilizes two different potentiometer styles. The Gain and Zero adjustments located on the front of the amplifier are more likely to be adjusted over the life of the product. For that reason they are physically larger and more robust. The industry standard “pot tweaker” is an ideal tool. The adjustment tool should have dimension on the order of 0.5mm (.020 inches) blade thickness and be 2.5 mm wide (0.1 inches).
- The adjustments that are usually made only once during initial setup are located behind a snap on access cover. This less obvious location helps to discourage alteration by unqualified persons. The infrequent adjustment of these potentiometers has warranted the use of smaller surface mount technology devices (SMT). A correspondingly narrower blade is needed (1.4 mm wide, 0.055” inches).
- When changing the internal jumper-switch settings, it is always advisable to change the settings with the 24 VDC power removed. If this is not possible, it becomes particularly

important to use a non-conductive tool to alter switch positions. Be sure that jumper-switch settings are fully positioned, to avoid accidentally putting it in an “in-between” state.

3.8 ADJUSTING AMPLIFIER COARSE ZERO

Two individual coarse offset adjustments have been provided. There is an adjustment for each Instrumentation Amplifier channel because each transducer can have unique offset voltages. The Coarse Zero adjustments are usually only adjusted one time, typically when the amplifier is installed, or transducers are replaced. Use the following steps:

1. Ensure that the IA gain settings have been set as described in section 2.5.
2. Set the Zero potentiometer on the front cover to mid-way (approximately 9 turns from either clutch actuation).
3. Set the Gain potentiometer from fully counter clockwise.
4. Temporarily place jumper switch J8 to the (2-3) position. This position excludes the RCH signal from contributing to the analog outputs so that only the LCH zero is represented on the analog output.
5. Connect a DC Voltmeter to inspect the +/- 10 VDC output signal for the “Zero” condition (NO calibration force on the transducers).
6. Adjust the LCH coarse potentiometer (P5) to achieve the desired “Zero” voltage. As this is a coarse adjustment, a voltage within 50 millivolts of the intended “Zero” should be adequate.
7. Return jumper-switch J8 to the (1-2) position for normal operation (where the sum of both channels is reported on the analog outputs).
8. Adjust the RCH offset using the RCH Coarse Zero potentiometer (P3).

3.9 ADJUSTING THE LCH-RCH BALANCE

This adjustment has been factory set for a “50/50” balance between channels. We recommend that you only adjust the LCH-RCH balance if it is necessary to better match the signals from transducers having substantially different output signals. To discourage unintended adjustment, the Balance potentiometer is located behind the access cover and is recessed slightly behind the LCH and RCH offset potentiometer, requiring a more deliberate placement of the adjustment tool.

Turning the Balance potentiometer clockwise, will boost the signal for the LCH and reduce the signal for the RCH. Because of this, we recommend that you make any needed balance adjustments early in the calibration cycle. Adjust the Balance potentiometer by observing the affect of an unequal application of calibration force upon the analog outputs. When adjusted correctly, the measured force reported by the analog outputs should be insensitive to the non-equal sharing of force between transducers.

3.10 GAIN AND FINE ZERO CALIBRATION

Use the following steps to make your final calibration adjustments:

1. Verify Zero on the analog Outputs for the “unloaded” condition and adjust the (Fine) Zero potentiometer to correct for any minor offset voltage.
2. Apply the calibration force to the transducer(s) and adjust the Gain potentiometer to achieve the desired span.
3. Verify linear operation of the transducer and amplifier by applying a force that falls somewhere between the zero and full-scale endpoints. The intent is not to conduct any calibration per se, but to confirm the hardware’s ability to accurately report a measured force.

We recommend that you focus only on achieving a particular voltage “span” between the load and unloaded forces by alternating between the two force levels. *Do not* repeatedly adjust the Zero potentiometer between measurements unless the offset voltage becomes excessive and interferes with achieving a valid output signal on the analog output. You should only adjust the final Zero after the desired Gain setting has been achieved.

These final calibration steps represent the minimal adjustments that might be required at periodic calibration intervals and typically involves only the Zero and Gain potentiometers accessible through the small holes in the front cover.

Appendix A. MANUFACTURERS DECLARATION OF CONFORMITY**Number: AO-90311**

Manufacturer: Cleveland Motion Controls, Inc.
7550 Hub Parkway
Cleveland, Ohio 44125
U.S.A.

Product Ultra Series Loadcell Amplifier
Models: MWI-13261 and MWI-13262
Classic Series Classic Loadcell Amplifier
Models: MWI-13467 and MWI-13466

Standards Used: EN 61326 (1998)
Electrical equipment for measurement, control and laboratory use
EMC requirements classification – Industrial locations

Test Report Number: EMR1686 of January 5, 2004

Tests Report: EU Compliance Services, Inc.
13275 Sperry Rd.
Chesterland, Ohio 44026

Declaration This product is in conformity with Council Directive 89/336/EEC
of 3 May 1989 on the approximation of the laws of the Member
States relating to electromagnetic compatibility based on test
results to the harmonized standards referenced.

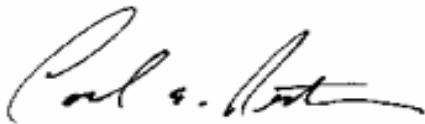

Carl Richter
Engineering Manager

Appendix B. CABLE GLANDS

Several manufacturers provide cable glands that can be used to ensure the integrity of the EMC requirements when installing this equipment in the enclosure. The objective of the cable gland is to provide a good mechanical entry into the enclosure to protect the cable and also provide an electrical bond the outer shield (screen) of the cable to the enclosure.

The following is a list of cable gland vendors and the range of cable sizes that each vendor can provide. This is not an endorsement or promotion of any particular vendor or manufacturer; the information is provided only to assist you in the application of the product described in this document.

Cable Gland Vendor	Cables
Sealcon 14853 E. Hinsdale Ave., Suite D Englewood, CO 80112, U.S.A. Tel: (303)699-1135 Fax: (303)680-5344 Tel: (800)456-9012	EMI-Proof Grounded Nickel Plated Brass Liquid Tight Strain Relief Fittings Standard and Feed-through types Cable diameters from 0.11 inches to 1.38 inches Metric (PG) or NPT thread types Optional metric (PG) to NPT adapters
GlobTek, Inc. 186 Veterans Drive Northvale, NJ 07647 Tel: (207)784-1000 Fax: (210)784-0111 Email: globtek1@idt.net URL: www.globtek.com	Standard, IP68 protection Index EMC Cable Glands Cable diameters from 6.0 mm to 20.0 mm Metric threads
Wiedmuller Tel: (800)849-9343 Fax: (800)794-0252	Bulkhead Cable Glands for Braid/Armour Termination Standard types KGC 1 Series Cable diameters from 1.8 mm to 39.9 mm Metric threads Optional washers and locknuts