

### EMAG 26

#### Specifications

Nominal torque	35	Nm	ft.lb	26
Minimal torque	0.33	Nm	ft.lb	0.25
Coil resistance - 20°C			Ohms	19
Rated current DC			A	1
Rotor inertia	0.79.10 <sup>-3</sup>	kg.m <sup>2</sup>	lb.ft <sup>2</sup>	18.4 10 <sup>-3</sup>
Weight	4.5	kg	lb	9.92
Heat dissipation Continuously sustained			W*	100

\* Heat dissipation is the mechanical power ( $P = cw$ ) maximum allowable.

- Easy Electric Remote Control
- Low Power Consumption
- High Level of Torque Stability
- Highest Torque Density
- No Dust
- Noiseless
- Easy Installation
- Maintenance-Free Bearing

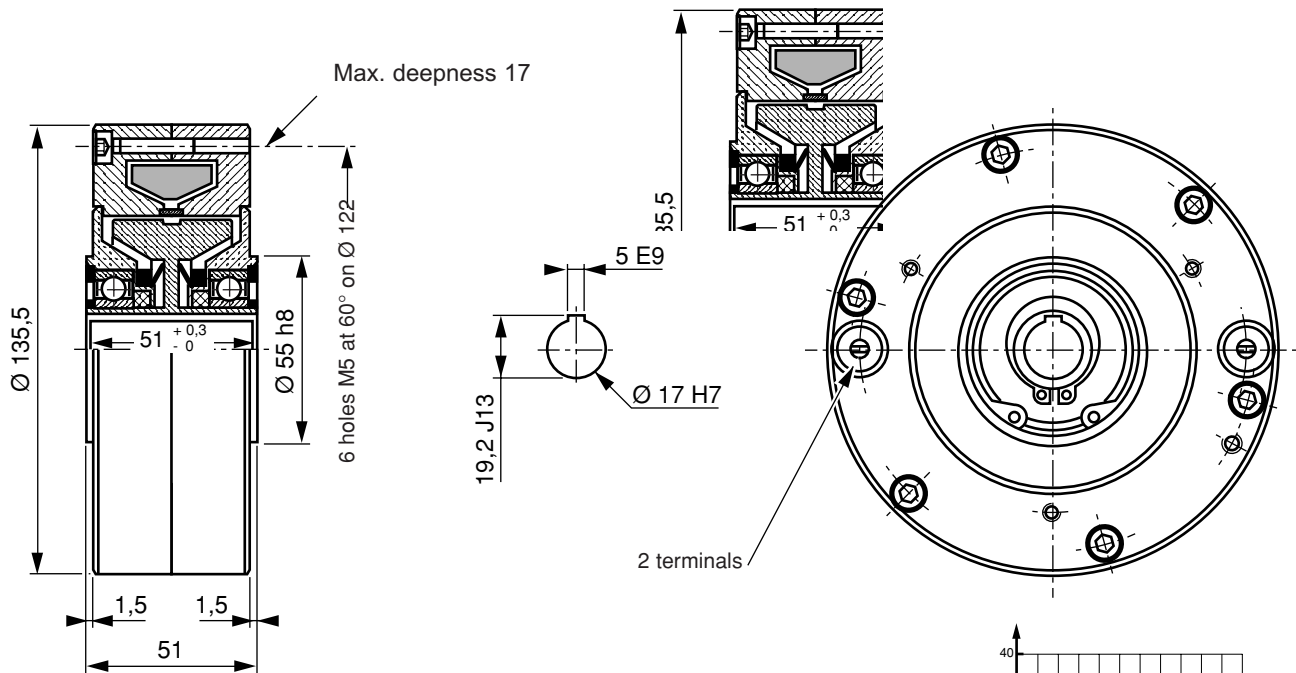

#### Application Notes

- Lubricated for life (other internal lubrication not required). The shaft should be lubricated upon assembly, to prevent seizing.
- For use with Cleveland-Kidder® 2 Amp, 24 VDC power supply (Model EMAG-PS2)
- The standard device is designed for horizontal shaft orientation, and a minimal speed of 60 RPM. Maximum speed is 3000 RPM (without exceeding the max. heat dissipation capability).
- For Engineering application, please contact our technical support.
- In normal use, the outside temperature of the device can increase up to 100°C, without damage.

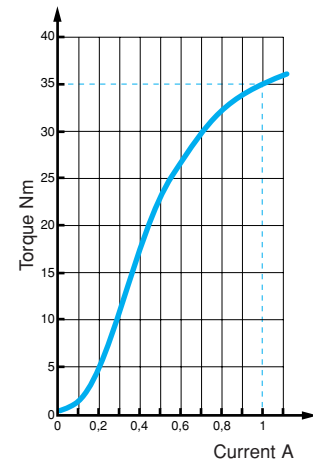

### EMAG 26H EMAG 26HB

#### Specifications

Nominal torque	35	Nm	ft.lb	26
Minimal torque	0.33	Nm	ft.lb	0.25
Coil resistance - 20°C			Ohms	19
Rated current DC			A	1
Rotor inertia	0.79.10 <sup>-3</sup>	kg.m <sup>2</sup>	lb.ft 2	18.4 10 <sup>-3</sup>
Weight	6.7	kg	lb	14.8
Heat dissipation			W *	
Continuously sustained with heat sink – H			200	
Continuously sustained with heat sink and blower – HB				1000

\* Heat dissipation is the mechanical power ( $P = cw$ ) maximum allowable.

- Easy Electric Remote Control
- Low Power Consumption
- High Level of Torque Stability
- Highest Torque Density
- No Dust
- Noiseless
- Easy Installation
- Maintenance-Free Bearing

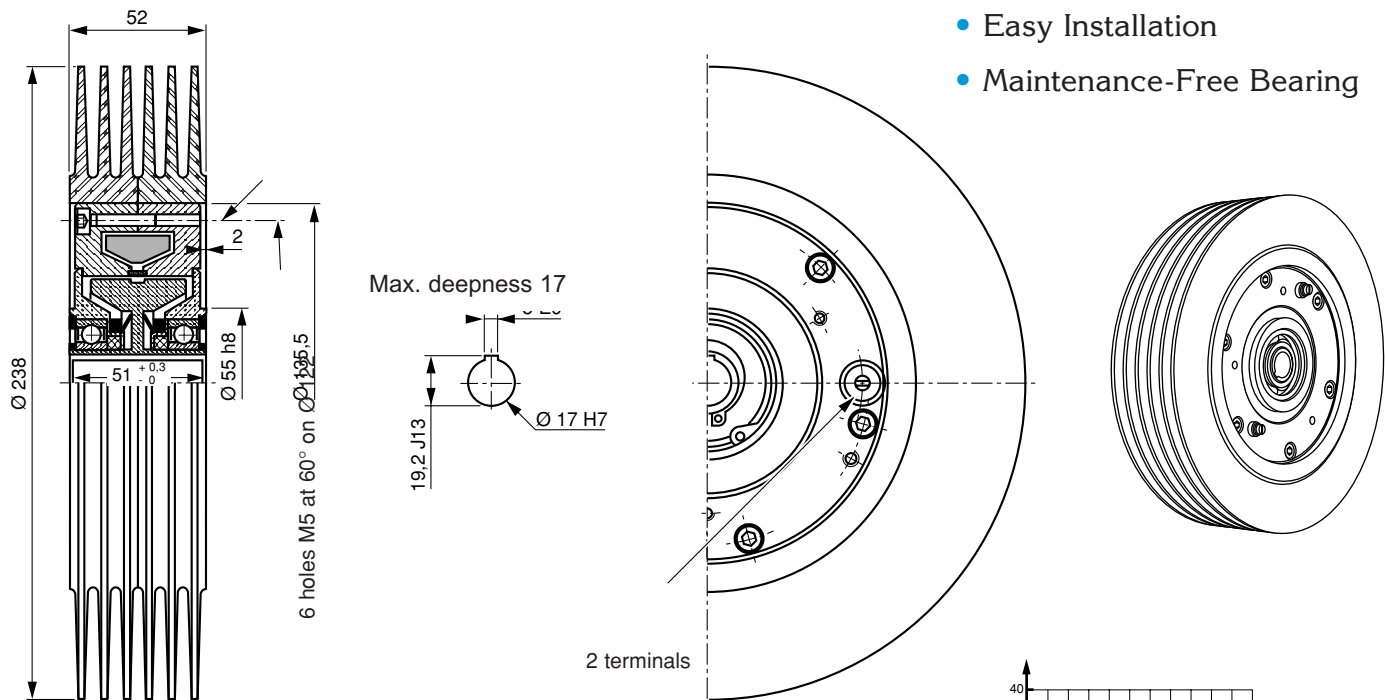

#### Application Notes

- Lubricated for life (other internal lubrication not required). The shaft should be lubricated upon assembly, to prevent seizing.
- For use with Cleveland-Kidder® 2 Amp, 24 VDC power supply (Model EMAG-PS2)
- The standard device is designed for horizontal shaft orientation, and a minimal speed of 60 RPM. Maximum speed is 3000 RPM (without exceeding the max. heat dissipation capability).
- For Engineering application, please contact our technical support.
- In normal use, the outside temperature of the device can increase up to 100°C, without damage.

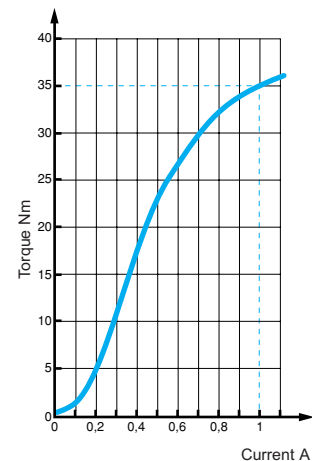

#### INDUSTRIAL PRODUCTS

7550 Hub Parkway  
Cleveland, OH 44125-5794  
Tel: 216-524-8800 or (800)-321-8072  
Fax: 216-642-2100  
www.CMCcontrols.com

