



ITT

Cleveland Motion Controls

**INSTRUCTION MANUAL
(MAN-70445-0)**

**FOR
ULTRA ISC CANTILEVER TRANSDUCER**

**MODELS: CLTEC, CLTSC, CLTECM
&CLTSCM**

REVISION

AA

REVISION HISTORY

Rev	ECO#	Author	Date	Description of Change
AA	--	WGW		As Released

This documentation may not be copied, photocopied, reproduced, translated, or reduced to any electronic medium or machine-readable format without explicit written permission from CLEVELAND MOTION CONTROLS.

Copyright © 2007 by ITT, Cleveland Motion Controls
 Burny/AMC Division
 7550 Hub Parkway
 Cleveland, Ohio 44125-5794
 Tele: 216.524.8800
 Fax: 216.642.2199

WARRANTY AND LIMITATION OF LIABILITY

All equipment is sold subject to the mutual agreement that it is warranted by the company to be free from defects of material and workmanship but the company shall not be liable for special, indirect or consequential damages of any kind under this contract or otherwise. The company's liability shall be limited exclusively to replacing or repairing without charge, at its factory or elsewhere at its discretion, any material or workmanship defects which become apparent within one year from the date on which the equipment was shipped, and the company shall have no liability for damages of any kind arising from the installation and/or use of the apparatus by anyone. The buyer by the acceptance of the equipment will assume all liability for any damages which may result from its use or misuse by the buyer, his or its employees, or by others.

The warranties of the company do not cover, and the company makes no warranty with respect to any defect, failure, deficiency, or error, which is:

Not reported to the company within the applicable warranty period, or

Due to misapplication, modification, disassembly, abuse, improper installation by others, abnormal conditions of temperature, dirt, or corrosive matter, or

Due to operation, either intentional or otherwise, above rated capacities or in an otherwise improper manner.

There are no other warranties, expressed or implied including the implied warranties of merchantability and fitness for a particular purpose.

BLANK

TABLE OF CONTENTS

1 PRODUCT OVERVIEW	1
1.1 GENERAL DESCRIPTION	1
1.2 FEATURES	2
1.3 HOW IS THE ULTRA ISC USED	2
1.4 CE EMC RESPONSIBILITY	2
1.5 GENERAL SPECIFICATIONS	3
1.6 PHYSICAL SPECIFICATIONS	3
1.7 ENVIRONMENTAL REQUIREMENTS	3
1.8 OPERATING CONDITIONS	4
1.9 EMC TECHNICAL RATINGS	4
1.10 EMISSION SPECIFICATIONS	4
1.11 SPECIFICATIONS (CANTILEVER TRANSDUCER)	5
1.12 BLOCK DIAGRAM OF ULTRA SERIES ISC AMPLIFIER MODULE	6
2 PRODUCT COMPONENTS	7
2.1 M12 MATING CONNECTOR	8
2.2 ELECTRICAL CONNECTIONS AND WIRING	8
2.3 CABLING	9
2.4 POWER SUPPLY REQUIREMENTS	10
2.4.1 Interface wiring	10
2.5 POTENTIOMETERS ADJUSTMENTS (IF NEEDED)	11
2.5.1 Correct Adjustment Tools	11
3 PRODUCT APPLICATION	12
3.1 FINAL CALIBRATION	12
3.2 SOFTWARE SCALING	13
4 INSTALLATION	14
4.1 RECEIVING AND UNPACKING	14
4.2 BEFORE INSTALLING THE TRANSDUCER,	14
4.2.1 Safety Considerations	14
4.2.2 Mounting Configurations	15
4.2.3 Mounting Hardware and Fastener Torque Recommendations	16
4.2.4 Mounting Dimensions	18
4.3 PRE-INSTALLATION PRECAUTIONS	19
4.3.1 Roll Length, Mass, Balance, Natural Frequency and Tracking	19
4.3.2 Roll Balance	20
4.3.3 Critical Roll Speed	20
4.3.4 Avoiding Damage To the Transducer	20
4.4 MOUNTING THE TRANSDUCER	21
4.5 MOUNTING THE SENSING ROLL	22
4.6 ORIENTING THE CANTILEVER TRANSDUCER	22
4.7 CHECKING THE TRANSDUCER MOUNTING	23
4.8 POWER-UP AND TESTING	23
4.8.1 Before Applying Power	23
4.8.2 Power Application	23
4.9 ADJUSTMENT TOOLS (ONLY IF NOT USING NUMERICAL CORRECTION)	24
4.10 GAIN AND FINE ZERO CALIBRATION	24
4.11 PROPER PRACTICES FOR APPLYING CALIBRATION FORCES	25

4.12 APPLYING FORCE TO TRANSDUCERS	26
4.13 CALIBRATION ACCURACY CONSIDERATIONS	26
4.14 FINAL CALIBRATION.....	27
4.15 EMC CONNECTIONS AND INSTALLATION	28
4.16 CABLE GLANDS	29

5 TROUBLESHOOTING 30

5.1 TRANSDUCER BENCH TESTING	31
------------------------------------	----

6 MANUFACTURERS DECLARATION OF CONFORMITY 32

WARRANTY

Cleveland Motion Controls warrants the goods against defects in design, materials and workmanship for the period of 12 months from the date of delivery on the terms detailed in the Cleveland Motion Controls, Inc. Terms and Conditions of Sale, document number AO-90131.

Cleveland Motion Controls, Inc. reserves the right to change the content and product specification without notice.

© 2009 in this document is reserved to:
Cleveland Motion Controls.
7550 Hub Parkway
Cleveland, OH 44125
216-524-8800 Phone
216-642-2199 Fax

INTENDED USERS

This Instruction Manual is to be made available to all persons who are required to configure, install or service the tension transducer equipment described in this manual or any other related activity.

FURTHER INFORMATION

For the latest product information, technical literature etc., visit our website at www.cmcccontrols.com

ATTENTION: The following information is provided merely as a guide for proper installation. Cleveland Motion Controls cannot assume responsibility for the compliance (or failure to comply) to any code (national, local or other) that prescribes the proper installation of this electronic device or associated equipment. A hazard of personal injury and/or property damage can exist if applicable codes and safety practices are not adhered to.

CONTACT INFORMATION AND SERVICE ASSISTANCE

For service assistance, have the following information available:

- Type of Cantilever Transducer (model # and serial #) you are using
- Maximum working force
- Purchase order number

You can contact Cleveland Motion Controls at:

Phone: 216.524.8800

Fax: 216.642.5159

WWW.CMCCONROLS.COM



Disassembly by improperly trained personnel may result in additional damage to these units. Should repairs be required or for warranty repairs, contact the Customer Service Department for a return authorization number before returning the units.

BLANK

1 PRODUCT OVERVIEW

1.1 GENERAL DESCRIPTION

The Ultra Series Integrated Signal Conditioning (ISC) Cantilever tension transducer (see Figure 1) outputs a +/- 10 VDC signal for reporting signals from strain gage-based load cells. Ultra ISC transducers include an Integrated Signal Conditioner (ISC) that is coupled directly to the “Ultra” type load cell employing semiconductor strain gages. This local processing reduces the signal degradation due to long wires to the driving displays or recording devices. **Note:** Customer must supply Roll shaft and bearings.



Because the output stage is free to float, voltage differences on the output side of the tension transducer with respect to protective earth ground.



Figure 1 Ultra Series Integrated Signal Conditioning (ISC) Cantilever Transducer

The Integrated Signal Conditioning (ISC) amplifier has a separate ground reference (common) for the output signals. The ground used by the output circuits is electrically separate from the ground return for the fixed 24Vdc supply. The 24Vdc supply input is protected against reverse polarity.

The Integrated Signal Conditioning (ISC) Amplifier uses an embedded Instrumentation Amplifier (IA) to amplify the millivolt level signals generated by the strain gage bridge, while effectively rejecting common-mode noise. Low drift Surface Mount Technology (SMT) components, Multi-layer Printed Circuit Boards (PCB) and optimum circuit topologies are incorporated to promote load cell signal integrity.

The Amplifier gain is adjustable over a 9.6:1 range to allow span calibration of the analog outputs.

A precision low voltage excitation source is provided for exciting the strain gage elements in the internal strain-gage bridge.

The use of galvanic isolation can aid in reducing noise pickup caused by ground loops in the field wiring and accommodates only limited voltage gradients between input and output sections of the application wiring.

1.2 FEATURES

Ultra ISC load cell features are:

- Factory Calibration promotes interchangeability
- Tension controller observation of individual load cell signals provides increased opportunity for advanced diagnostics and calibration.
- Self contained precision excitation circuit eliminates the need for the expense and complication of remote sense
- 24V supply has reverse polarity protection
- Analog output buffer designed to accommodate capacitive cable loads.
- Floating strain-gage and output stage allows “stacking” ISC outputs for simple summing.
- Sealed enclosure and M12 connector provide environmental protection
- Industry standard M12 allows use of readily available molded cordsets

1.3 HOW IS THE ULTRA ISC USED

The Ultra ISC load cell has been developed for those customers who desire to send the amplified transducer signal directly into their Controller, PLC, PAC, Drive, or Local I/O.

The Ultra ISC load cell is shipped preset from CMC with 0 volts representing no load, and 10 volts representing the 100% full rating of the transducer. (Example: A 100 lb Ultra ISC transducer with no load outputs 0 volts. With a 100 lb. load the output is 10 VDC when loaded in one direction and -10VDC when loaded in the opposite direction.)

1.4 CE EMC RESPONSIBILITY

The Integrated Signal Conditioning (ISC) Amplifier Ultra Series ISC module embedded in the load cell can be considered a component performing a direct function and therefore is subject to the provisions of the EMC Directive.

To assist manufacturers, suppliers, and installers of relevant apparatus, this amplifier module is compliant to EN61326:1997 when installed according to these instructions. Manufacturers, suppliers, and installers of relevant apparatus may use this compliance as a contributing basis for their own justification of overall compliance with the EMC Directive.

Before installing the Ultra Series ISC Amplifier you must clearly understand who is legally responsible for conformance with the EMC Directive. Misappropriation of the CE mark is a criminal offense.

1.5 GENERAL SPECIFICATIONS

Item	Specification	Comments
Input Supply		
Power Supply Requirements	21.6-26.4 VDC @ 50mA	Basic Isolated Amplifier
Load Cell (Transducer)		
Transducer Excitation (Vexc)	3.0 VDC FIXED	Internally supplied.
Amplifier		
Calibration Range	Min. 0.9 - Max. 9	Multi-turn Gain adjustment provided.
Zero Adjustment	Output Zero Preset at CMC – Accessible by user if absolutely necessary	0V=Zero force on beam
Span (Gain) Adjustment	Preset at CMC – Accessible by user if absolutely necessary	Adjustments provided
Amplifier Output Signal	+/-10 VDC @ 2 mA	+/-10 is undamped signal
Isolation		
Isolation	+/- 50 V max.	output circuit potential not to exceed 50 V from protective earth potential

1.6 PHYSICAL SPECIFICATIONS

Item	Specification	Comments
Enclosure Type	Integrated Signal Conditioning mountable with special adjustments accessible from the surface. Remove sticker or screw to access the setup potentiometers.	Extruded aluminum enclosure just behind the M12 connector.
ISC Enclosure Size	Base: 26 mm wide by 26 mm high Length:43 mm	1.0 inches (width) by 1.0 inches (height) 1.7 inches (depth)
Weight – Basic Amplifier	50 Grams	2.5 ounces
Connector	4 Pin M12 Quick-Connect	M12 Quick-Connect 4 Pin, DC Keyed

1.7 ENVIRONMENTAL REQUIREMENTS

Requirement	Description
Enclosure	IP50 NEMA 1
Operating temperature	0 to 70 degrees C 32 to 158 degrees F
Humidity	Non-condensing 85% at 55 degrees C 85% at 132 degrees F
Altitude	1000 meters 3300 feet
Atmosphere	Non-flammable, non-corrosive and dust free
Storage temperature range	-30 to 90 degrees C -22 to 194 degrees F
Transport temperature range	-40 to 80 degrees C -40 to 176 degrees F

1.8 OPERATING CONDITIONS

Condition	Isolated Signal Conditioning Amplifier
Installation category	Category III
Pollution	Pollution Degree 2
Input supply	Earth (Ground) referenced
Protection	Enclosure mounted

1.9 EMC TECHNICAL RATINGS

Port	Phenomenon	Test Standard	Level	Test Standard
Enclosure	ESD	EN 61000-4-2:	8KV AD, 1KV CD	EN 61326:1997
Enclosure	RF Field	EN 61000-4-3	10V/m, 1 Khz AM	EN 61326:1997
Transducer Leads	Fast Transient Burst	EN 61000-4-4	1kV	EN 61326:1997
Output Leads	Fast Transient Burst	EN 61000-4-4	1kV	EN 61326:1997
Transducer Leads	Conducted Immunity	EN 61000-4-6	3V/m	EN 61326:1997
Output Leads	Conducted Immunity	EN 61000-4-6	3V/m	EN 61326:1997

1.10 EMISSION SPECIFICATIONS

Port	Phenomenon	Test Standard	Level	Generic Standard
Enclosure	Radiated	EN 61326:1997	Class A	EN 61326:1997



The levels of performance indicated are achieved when the Isolated Signal Conditioning Amplifier is installed by using the instructions and specifications outlined in this document.

1.11 SPECIFICATIONS (CANTILEVER TRANSDUCER)

Item:	Specification:			
Transducer Weight	1T ALUM	1T STEEL	2T STEEL	
	1.9 lbs. 0.86 kg.	2.7 lb. 1.23 kg	3.7 lb. 1.68 kg	
Weight + Mounting Kit	1T ALUM	1T STEEL	2T STEEL	
	Flange	2.9 lbs. 1.32 kg.	3.7 lbs. 1.68 kg	5.3 lbs. 2.41 kg
	Bearing	2.3 lbs. 1.05 kg.	3.1 lbs. 1.41 kg.	4.2 lbs. 1.91 kg.
	Pillow Block	4.8 lbs 2.18 kg.	5.6 lbs. 2.54 kg.	7.9 lbs. 3.59 kg.
Material	Strain Sensing beam - heat treated 4140 alloy steel or 2024 T81 Aluminum Body - 1117 Low Carbon steel			
Finish Material	Corrosion resistant Zinc plated with clear Chromate			
Gage Type	Semi-conductor strain gage, high gage factor (100 nominal)			
Connector Type	M12 Quick-disconnect, 4 conductor, DC keyed			
Excitation Voltage	Internally generated			
Nominal Output Signal at Rated MWF	Factory calibrated @ 0V= 0 Force; 10V=100% MWF			
Non-destructive Overload	150% MWF			
Ultimate Overload	300% MWF (typ) (500% for ratings > 25 lb-f			
Maximum Voltage*, Base (Ground)	50 Volts peak			
Angular Deflection	0.01 inches Max. as measured at the far end of the sensing roll with maximum load present. (Roll Journal deflection not included)			
Operating Temperature Range	0 to 70 degrees C 32 to 158 degrees F			

* 24V input circuit or +/- 10V output circuit

1.12 BLOCK DIAGRAM OF ULTRA SERIES ISC AMPLIFIER MODULE

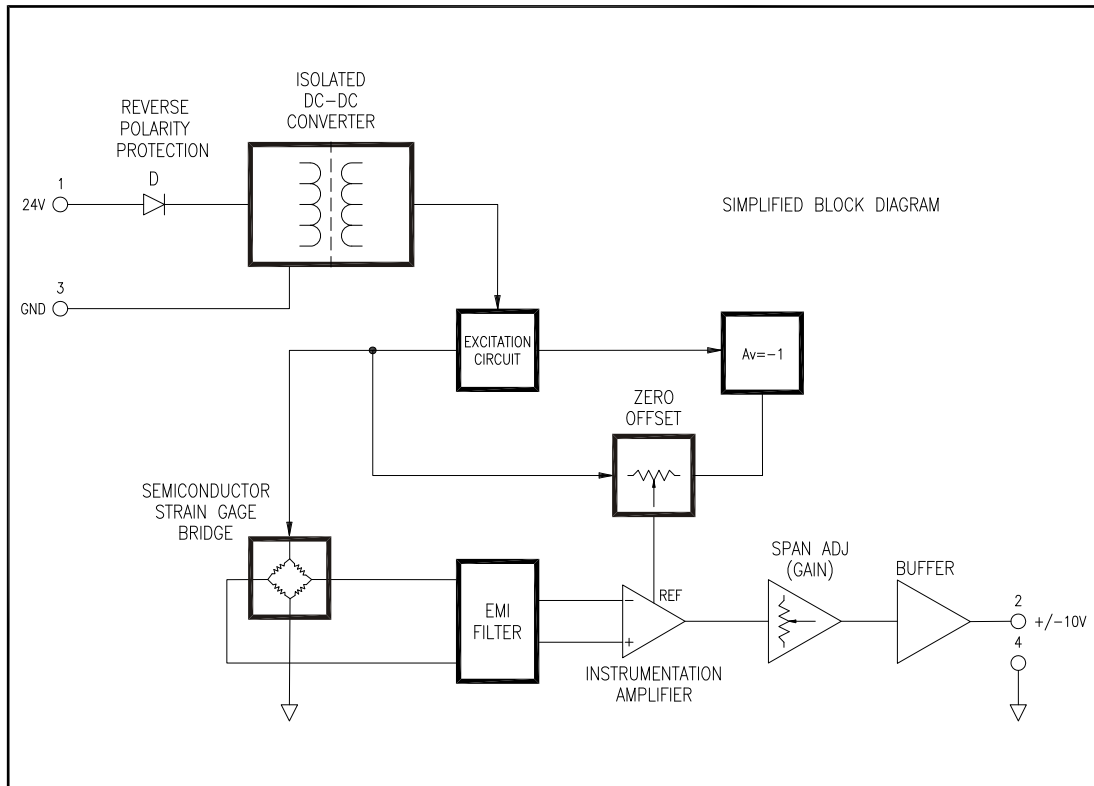

Figure 2 Block Diagram of Ultra Series ISC Amplifier Module

2 PRODUCT COMPONENTS

The Ultra Series ISC Cantilever Tension Transducer (see Figure 3 and Figure 4) consists of a housing that contains the amplifier and power supply boards that are coupled directly to an “Ultra” type load cell. There is an M12 connector to send amplified transducer signals into the analog input of a tension controller, PLC, PAC, drive or local I/O. This housing has two access holes for gain and zero potentiometer adjustments if necessary.

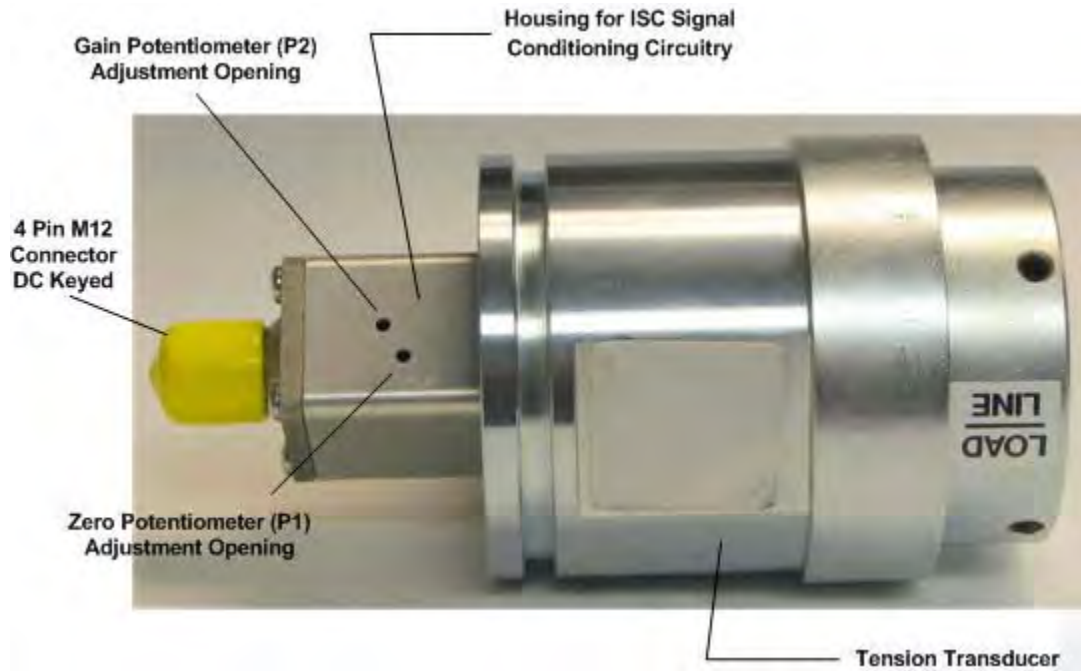

Figure 3 Ultra Series ISC Cantilever Tension Transducer Model EC

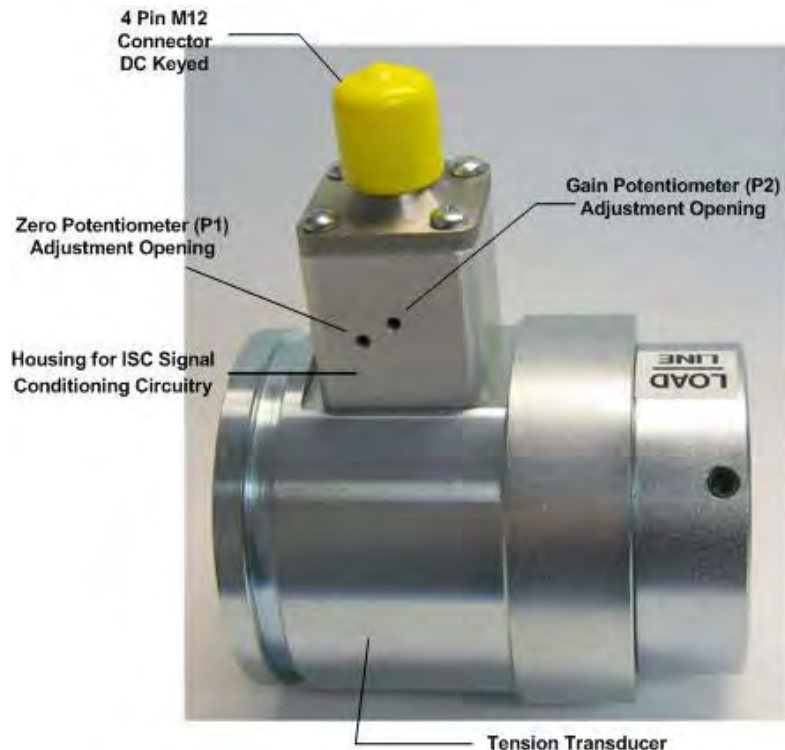

Figure 4 Ultra Series ISC Cantilever Tension Transducer Model SC

2.1 M12 MATING CONNECTOR

The M12 connector used on the Ultra Series ISC amplifier is a four-pin, DC keyed, male connector that mates directly with the molded cordset offered by Cleveland Motion Controls. Table A lists the pin numbers, signal, Function, wire colors and any notes that apply:

When mating the connector, align the keying mechanism and pins so that they enter the socket without you having to apply excessive force. Use your fingers to sufficiently tighten the coupling nut enough to ensure an adequate seal and to discourage accidental loosening.

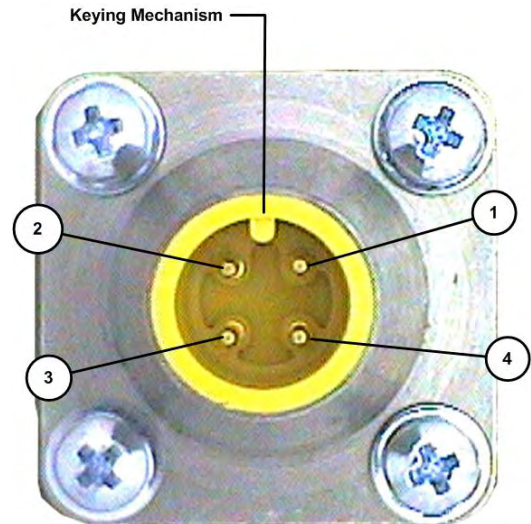

Figure 5 - Front View of M12 Connector

Pin #	Signal	Function	Wire Color	Notes
1	24 VDC	Power Supply source 24 Vdc	Brown	+24 VDC @ 50 mA max
2	+/- 10V OUT	Voltage Signal Output Undamped bi-polar tension signal	White	max. load 2 mA
3	0V RET	Power Supply Return	Blue	Must not exceed 25 volts from P.E.
4	COMMON	Signal Output Return	Black	Common for +/- 10V an analog output. Must not exceed 25 volts from P.E.

Table A M12 Pin Numbers and Cable Colors



If you choose to make your own cables or need to repair damaged connectors, you can purchase a separate mating connector from Cleveland Motion Controls. To order, use CMC part number, X43-34338.



A fuse with a rating of 0.25A must be used in the fixed 24 VDC supply lead to limit potential damage to the amplifier in the event of circuit malfunction. Example: Bussman GMA-250-R



Transducers (load cells) use strain gages which have limited insulation levels to ground (earth). This requires that the COM terminals be referenced to ground (earth) to prevent damage to the transducers (load cells).

2.2 ELECTRICAL CONNECTIONS AND WIRING

Refer to Figure 6 Installation Wiring Diagram for making the transducer to power supply and tension controller connections. Make certain that:

- The cables do not interfere with the web path, and that they are away from power transmission, gearing or other moving parts.
- You exercise care when routing the cables to avoid pick-up from noise-radiating power cabling (motor armature leads, AC main wiring, etc).

- In environments with severe electromagnetic noise, it may be necessary to route the cables inside metallic conduit.
- Polarity changes are accommodated by reversing the physical orientation of the transducer, by interchanging the black and white output wires, or by changing the sense parameter settings in the user's application software.

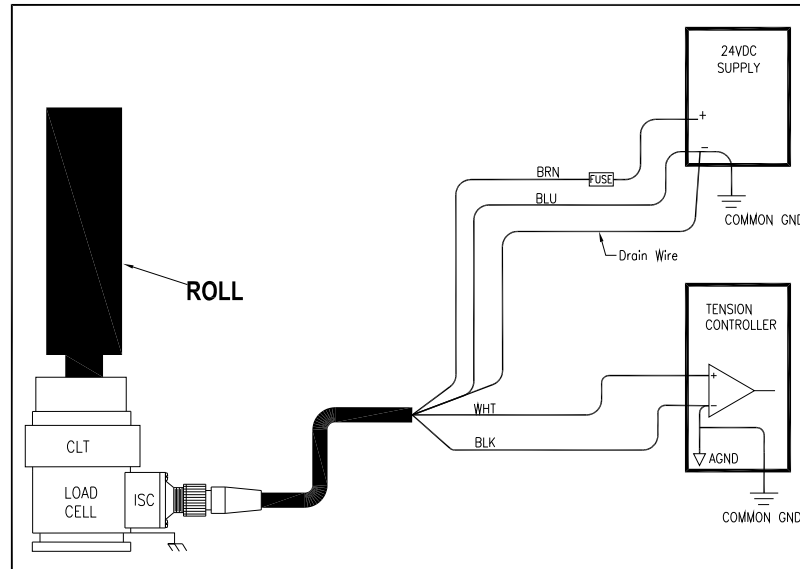

Figure 6 Installation Wiring Diagram

2.3 CABLING

Important: Most start-up problems are the result of mis-wiring or failure to reference the detailed information in this manual.

The connector for the ISC is a standard 4-pin M12 quick-connect connector keyed for DC operation. Molded cordsets are readily available (see Table B) that can provide a direct connection between the ISC equipped Tension Transducer, the required 24 VDC supply and tension controller (PLC, Tension Indicator, Analog Input Module, etc). Ready-made PUR (polyurethane) jacketed cordsets are available in different lengths and different connector orientation (straight or right-angle) from Cleveland Motion Controls. **It is advisable to employ an overall outer shield (or place cable in a metallic conduit) for noise rejection in environments with high levels of electromagnetic interference.**

The wire gage should be a minimum of 24 AWG to aid in minimizing undesirable voltage drops. An overall outer shield is required, with the shield connected to ground at the tension controller through as short a connection as possible. The short connection is essential in minimizing parasitic inductance and thereby maximizing the shielding effectiveness at high frequencies.

Exercise care in routing the cable to minimize electromagnetic interference from noise generating wiring and equipment.

Table B lists the part numbers and descriptions for these available cordsets (Get from Web marketing):

Length	Cordset Part Number	Connector Orientation	Cordset Part Number	Connector Orientation
3M	X44-33975-010	Straight	X44-33976-010	Right-Angle
8M	X44-33975-026	Straight	X44-33976-026	Right-Angle
16M	X44-33975-052	Straight	X44-33976-052	Right-Angle
24M	X44-33975-078	Straight	X44-33976-078	Right-Angle
32M	X44-33975-105	Straight	X44-33976-105	Right-Angle
48M	X44-33975-157	Straight	X44-33976-157	Right-Angle

Table B Cordset Part Numbers

2.4 POWER SUPPLY REQUIREMENTS

For best performance, a regulated DC power supply that provides a nominal 24 VDC and at least 50 mA should be used.

Important: Pay particular attention to the power supply for susceptibility to the effects of conducted and radiated energy from noise sources. Every effort should be made to provide stable voltage to the amplifier using correct wiring practices and filters. To protect against circuit damage, include a 0.25 Amp fuse in the power supply output lead to each amplifier in case of amplifier or power supply malfunction.



The power source for the power supply shall be fused at the proper rating to prevent over current in the supply leads due to a power supply failure.

Output voltage from the supply should be within +/- 10% of 24 VDC. Component stress due to excessive supply voltage may damage components and prolonged operation with a higher than necessary voltage will increase the internal temperature of the circuitry within the ISC. Supply voltages that are excessively low (either due to a low supply set-point or excessive IR drop of voltage arising by long cable runs) can result in “brown-out” of internal regulated supply voltages. This “brown-out” may be evident by the +/- 10V analog output being **clipped** at some voltage below 10V. Keep in mind that voltage drops due to long cable runs may drop the voltage by nearly a half a Volt (250 feet of 24 AWG cable carrying 30 mA will loose 0.4 V).

Although the amplifier provides limited galvanic isolation between the 24 VDC supply circuit and the strain-gage amplifier circuit, it is only intended as a mechanism to avoid “ground loop” interference. The 24 VDC supply should always have its output return referenced to P.E. (protective earth), so that uncontrolled potentials are not imposed between the 24 VDC supply circuit and the load cell case.

For optimum performance, the DC supply voltage should be free from excessive ripple voltage or transient excursions.

2.4.1 INTERFACE WIRING

The load in this connection may be an indicator, recorder, data acquisition device or the analog input terminals of a control device such as a DC drive or a programmable logic controller. The output signal at this terminal is undamped and provides a direct response to changes in the transducer (load-cell) load. Note that the cable’s shield drain wire should be connected at only one end, preferably at the “receiving end” (i.e. common ground at the PLC Analog Input etc.).

The pair of wires associated with the amplified transducer signal are generally separated out from the 24VDC supply wires at the point where they get routed toward the tension controller.

For most M12, DC keyed molded cordsets, the wire colors associated with the #1 and #3 pins is BRN and BLU respectively.

For most M12, DC keyed molded cordsets, the wire colors associated with the #2 and #4 pins are WHT and BLK respectively. These WHT and BLK wires provide the amplified tension signal transmitted as a +/- 10 VDC Full Scale

analog signal from an internal op-amp (operational amplifier) buffer stage. The BLK wire has the signal return and the WHT wire is the amplifier output. Resistive loads drawing up to 5 mA of current are allowable.

One of the most common ways of reversing the sense of the load cell signal is to invert the mechanical orientation of the load cell body itself. If this is impractical, it is possible to interchange the BLK and WHT signal wires, as the load cell amplifier and output stage is essentially floating with respect to the 24 VDC supply ground. Note however that the voltage potential cannot be allowed to float “unbounded”, and that connection to line potential drive circuits is not permissible (and potentially hazardous).

2.5 POTENTIOMETERS ADJUSTMENTS (IF NEEDED)

The gain and zero adjustments are factory preset but accessible by the user for adjustment if absolutely necessary. Adjustment holes to access these potentiometers are visible on the side of the housing. Adjustments can be made by removing the sticker cover around the amplifier enclosure. Refer to Figure 3 to locate the zero and gain adjustment holes.

Table C lists these potentiometers, their reference designator, and a description of their functions. For information on the correct adjustment tool to use, refer to section 2.5.1 in this document.

Potentiometer	Reference Designator	Function
GAIN	P2	This potentiometer is preset but accessible by the user for adjustment if absolutely necessary. It provides a 10:1 “vernier” adjustment of the amplifier gain. It is a multi-turn potentiometer, with clockwise rotation causing an increase in amplifier gain. When turned fully counter clockwise, the potentiometer causes the amplifier stage to provide the minimum gain.
ZERO	P1	This potentiometer is preset but accessible by the user for adjustment if absolutely necessary. It provides a zero (offset) adjustment. It is a multi-turn potentiometer, with clockwise rotation causing a positive shift in the analog outputs. It should be set mid-way prior to setting the ZERO adjustment.

Table C Potentiometer Adjustments

2.5.1 CORRECT ADJUSTMENT TOOLS

A small flat-bladed “jeweler’s” screwdriver is required. The overall diameter should be no larger than 0.062” The thickness of the blade flat should be no greater than 0.012”. Ideally, a non-conductive tool (plastic or ceramic) provides the safest approach by minimizing the generation of minute metallic shards that are made when a metal blade accidentally scuffs the aluminum housing.

The Zero is normally adjusted first while the load cell is in the No-Load condition (i.e. with no tension in the web). The calibration forces are then applied to the transducer and then the Gain potentiometer adjusted to achieve the desired scale factor. It is advisable to look for a particular step change between load and no-load conditions and adjust the step size independent of a particular zero point. Only after the desired scale factor is achieved, is it then best to adjust the final zero point using the Zero adjustment.

Following adjustment, it is important to seal the adjustment holes for continued protection from contamination. A small piece of adhesive backed tape can be used to reseal.

3 PRODUCT APPLICATION

The Ultra Series ISC Cantilever Cell Transducer utilizes a twin sensing beam. Conversion from mechanical strain to an electrical signal is accomplished using semiconductor-based, piezoresistive strain gage elements. The Full Wheatstone Bridge configuration provides an electrically balanced output yielding twice the amount of signal swing as half-bridged transducers operated at the same excitation voltage. Integral span compensation is used to correct for temperature induced gain changes.

Ultra Series ISC Cantilever Cell Transducers can be mounted four different ways: Flange (FL), Stud (S), Pillow Block (PB) and Bearing (BB) that incorporate their own low friction bearings.

Figure 7 shows these four mounting types. Refer to Section 4.2.2 for more information on Mounting Configurations. Although this figure represents mounting types for the Ultra Cantilever Transducer, the same types of mounting configurations are also applicable to Ultra ISC Cantilever transducers..

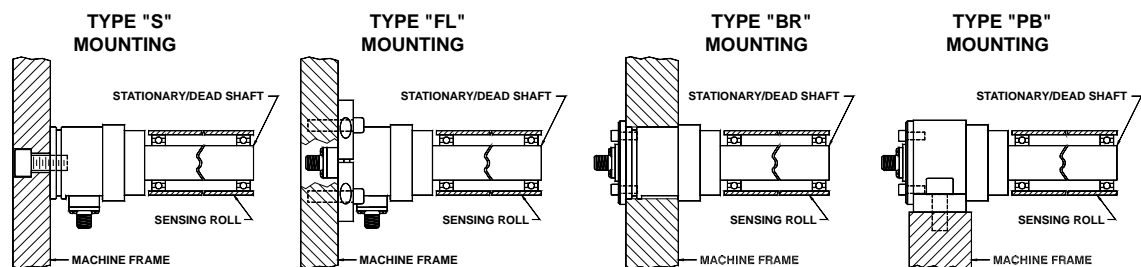

Figure 7 Cantilever Cell Transducer Mounting Types

The Ultra ISC has been developed for those customers who desire to send the transducer signal directly into their Controller, PLC, PAC, Drive, or Local I/O. **It is responsibility of the customer to write this software.**

3.1 FINAL CALIBRATION

When calibration is done through application software within the target controller, the greatest calibration accuracy is achieved through the use of individual gain and offset parameters for each of the two transducers (which generally are used in pairs). By using separate analog inputs and separate gain and offset parameters, you can correct for any transfer function differences arising from subtle mounting variations intrinsic to transducer output variations. If however the load cells are summed first and then digitized, the matching of load cell outputs (as affected by such things as load cell orientation relative to the wrap angle) becomes more critical.

The tradeoff between hardware cost and accuracy will impact the decision as to which approach users decide to take.

3.2 SOFTWARE SCALING

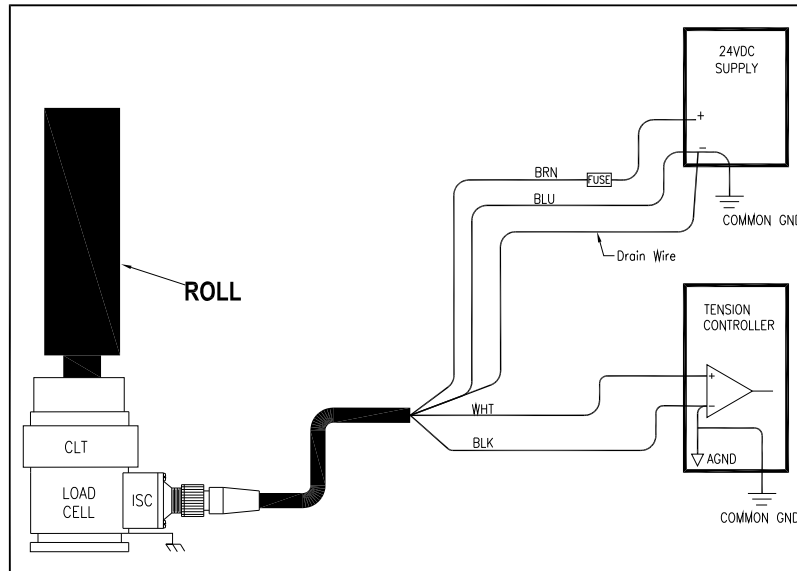

Figure 8 Software Scaling

Here is a simple example of software scaling

Command	Description
Sample (digitize) CLT_CH and store	; Store digitized Cantilever CH.
ADD CLT CH_OFFSET to CLT_CH parameter	; Cantilever CH_OFFSET is the zero correction constant.
Multiply offset corrected CLT CH parameter by CLT CHGAIN	; This is the composite tension feedback

Note that sometimes, over-sampling and filtering can be used to generate a robust tension feedback parameter despite brief disturbances (either mechanical or electrical).

4 INSTALLATION

4.1 RECEIVING AND UNPACKING

After receiving the Transducer you should:

- Carefully, unpack and inspect the equipment;
- Compare the received shipment with the packing list
- Make sure that you have the correct transducer model, hub diameter and mounting kit
- Report any damage to the carrier and your CMC representative
- Store equipment that will not be used in a clean, dry location
- Take appropriate precautions to prevent moisture, dust and dirt from accumulating in storage and installation areas

4.2 BEFORE INSTALLING THE TRANSDUCER,

Before installing the Transducer, perform the following steps:

1. Review the Safety Considerations (Section 4.2.1).
2. Review the Mounting Configurations (Section 4.2.2).
3. Assemble the Mounting Hardware and review the Fastener and Torque information (Section 4.2.3).
4. Reference the Mounting Dimensions (Section 4.2.4).



- *Failure to follow precautions can result in serious damage to the Ultra ISC Series Transducer and possibly void the warranty!*
-

4.2.1 SAFETY CONSIDERATIONS

Don't let safety be an afterthought. Before beginning calibration of transducers, review and follow applicable policies and procedures to ensure worker safety. Machinery must be in a safe state, and you should be aware of additional hazards that can arise when calibrating higher force transducers. The following points are important to remember:

- When dead weights are used to produce a force, always wear steel-toed shoes.
- When manually handling weights, use safe lifting practices to avoid injury.
- Size any cordage or straps with an ample safety factor to reduce the chances of failure and falling weights.
- Consider where the cords and weights will travel should a failure occur.
- Check that all hardware is mounted with the appropriate fasteners (thread size and pitch, fastener grade, length of thread engagement).

To ensure proper installation and operation of the system, keep the following points in mind:

- Exercise care to avoid overstressing the transducer when handling partially mounted rolls. Even relatively short rolls can afford an impressive mechanical advantage over the transducer.
- Bolting the transducer to a non-flat surface can cause deformation of the transducer body and degrade the quality of the tension signal.



- *Failure to follow precautions can result in serious damage to the Ultra ISC Series Transducer and possibly void the warranty!*
-

4.2.2 MOUNTING CONFIGURATIONS

Ultra Series ISC Cantilever Transducers can be mounted on either the inside or outside of the machine frame depending on the model type purchased (refer to Figure 9 and Table D). When choosing a mounting configuration, evaluate your options by taking the following points into consideration:

- Model type
- Safety
- Machine Frame orientation
- Ease of Assembly

Although Figure shows mounting types for the Ultra Cantilever Transducer, the same types of mounting configurations and connector locations are also applicable to Ultra ISC Cantilever transducers.

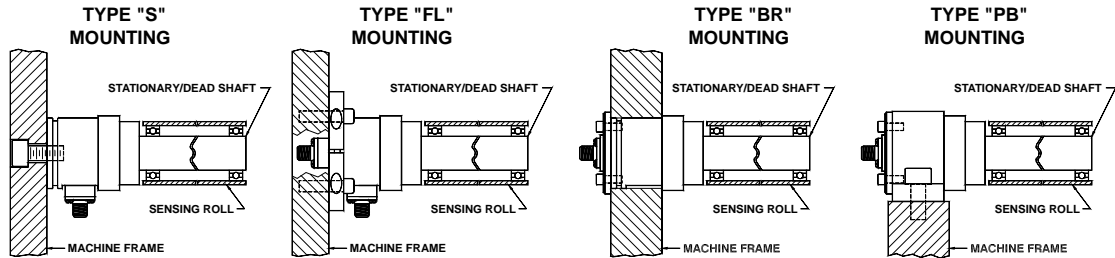

Figure 9– Types of Mounting Configurations

Table D – Mounting Type and Connector Location

When using this type of Mounting Configuration:	The Connector can be located at:	
	End	Side
Flange (FL)	X	X
Stud (S)		X
Pillow Block (PB)	X	
Bearing (BR)	X	

The tension-sensing roll *must not* be located where the web wrap angle can vary, or the transducer will not interpret the tension properly as the angle varies. If a variance in the wrap angle occurs, it is sensed by the transducer as a tension change and the change is indicated on the tension indicator. In cases where it is impossible to mount the transducer where the wrap angle does not vary, the change in indicated tension that results should be calculated and if sufficiently small, can be disregarded.

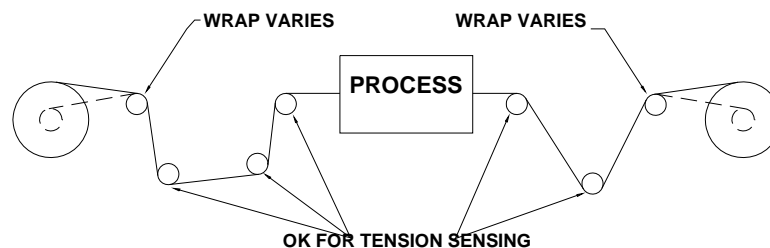

Figure 10 - Example of Varying Wrap Angles

4.2.3 MOUNTING HARDWARE AND FASTENER TORQUE RECOMMENDATIONS

Table E provides you with guidelines to refer to when determining torque values for clean and dry fasteners. Keep in mind, however, that several variables can influence the “optimum” torque to be used in a given situation, and Table E should be used only as a general guide. If you are unsure of the proper torque values to use, consult the machine manufacturer for specific recommendations.

- Use quality alloy steel fasteners (SAE Grade 8, ISO property grade 10.9).
- If the fastener threads are lubricated, reduce the torque amount. Use a torque value that is 70 percent of that listed in Table E. For example, if you are using a lubricated 1/2-13NC base stud on a SC-1T transducer, reduce the torque amount of 45 ft-lb to 31 ft-lb.
- Transducers operated at lower forces may not require the higher clamping forces obtained at the cited torque values.

Table E – Torque Value Guideline Tables

Transducer Models:	Fastener Type:	Fastener Thread (SAE):	Torque:
CLTEC-1T CLTSC-1T	Base Stud	1/2-13 NC	45 lb-ft
	Base Bolt (Bearing and Pillow Block)	1/4-20 NC	70 lb-in
	Shaft Adapter-Aluminum Shaft Adapter-Steel	10-32 NC 10-32 NC	18 lb-in 24 lb-in
	Shaft Set Screw: Aluminum Steel	10-32 NC 10-32 NC	18 lb-in 24 lb-in
	Flange Bolt	3/8-16 NC	15 lb-ft
	Pillow Block Bolt	1/2-13 NC	45 lb-ft
	CLTEC-2T CLTSC-2T	Base Stud	5/8-11 NC
Base Bolt (Bearing and Pillow Block)		1/4-20 NC	95 lb-in
Shaft Adapter		1/4-20 NC	70 lb-in.
Shaft Set Screw		1/4-20 NC	70 lb-in.
Flange Bolt		1/2-13 NC	25 lb-ft
Pillow Block Bolt		1/2-13 NC	45 lb-ft
Transducer Models:	Fastener Type:	Fastener Thread (Metric):	Torque (N-m):
CLTECM-1T CLTSCM-1T	Base Stud	M12-1.75	35
	Base Bolt (Bearing and Pillow Block)	M6-1	4
	Shaft Adapter-Aluminum Shaft Adapter-Steel	10-32 NC 10-32 NC	2 2.7
	Shaft Set Screw: Aluminum Steel	M5-0.8 M5-0.8	2 3
	Flange Bolt	M10-1.5	11

CLTECM-2T CLTSCM-2T	Base Stud	M16-2	65
	Base Bolt (Bearing and Pillow Block)	M8-1.25	8
	Shaft Adapter	1/4-20 NC	6
	Shaft Set Screw	M6-1	4
	Flange Bolt	M12-1.75	18



Mechanisms used for industrial automation can tax even the best threaded fasteners. You can improve the likelihood that bolts and shafts remain secure by using suitable anaerobic “thread lockers” during the final assembly.

4.2.4 MOUNTING DIMENSIONS

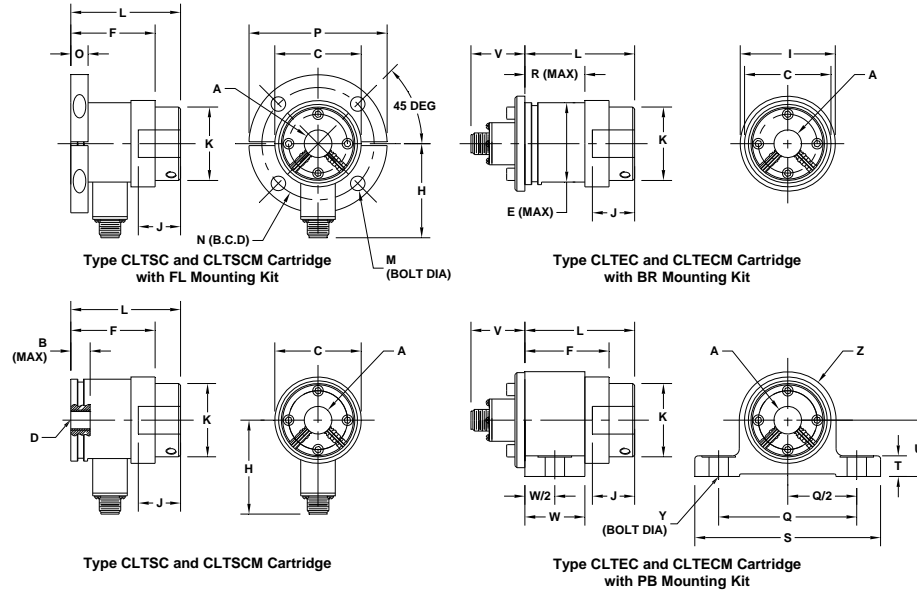

Mounting dimensions for Inch Hardware: CLTEC and CLTSC

Designator:	1T	2T
A	Per Adapter See Table F	
B	0.55	0.60
C	2.50	2.75
D	1/2-13	5/8-11
E	2.375	2.625
F	2.44	2.85
G	-	-
H	2.76	2.23
I	2.75	3.00
J	1.10	1.30
K	2.13	2.312
L	3.12	3.665
M	3/8 Dia.	1/2
N	3.25	3.50
O	0.50	0.62
P	4.00	4.50
Q	4.00	5.00
R	1.74	1.87
S	5.38	6.12

Mounting dimensions for Metric Hardware: CLTECM and CLTSCM

Designator:	1T	2T
A	Per Adapter See Table G	
B	14.0	15.2
C	63.5	69.9
D	M12-1.75	M16-2
E	60.33	66.67
F	62.0	72.4
G	-	-
H	70.1	56.6
I	69.9	76.2
J	27.9	33.0
K	54.0	58.7
L	78.7	93.1
M	M-10	M-12
N	82.55	88.90
O	12.7	15.7
P	101.6	114.3
Q	101.6	127.0
R	44.2	47.5
S	136.6	155.4

T	0.58	0.68	T	14.7	17.3
U	1.63	1.94	U	41.3	49.2
V	1.70	1.02	V	25.9	25.9
W	1.75	1.88	W	44.5	47.7
X	-	-	X	-	-
Y	1/2	1/2	Y	M-12	M12
Z (Radius)	1.50	1.70	Z	38.1	43.2

*Maximum shaft diameter 30.00 mm

Figure 11 – Mounting Dimensions

ID Recommendations for Cantilever Adapters for Inch or Metric Shaft Diameters

For Shaft Diameter (in.)	Cantilever Adaptor ID (in.)
1/2	.5005-.5015
5/8	.6255-.6266
3/4	.7506-.7517
1	1.0007-1.0020
1.125	1.1257-1.1271
1.25	1.2508-1.2522
1.5	

Table F

For Shaft Diameter (mm.)	Cantilever Adaptor ID (in.)
17	.6699-.6709
20	.7880-.7890
25	.9848-.9859
30	1.1818-1.1830
35	1.3788-1.3800

Table G

4.3 PRE-INSTALLATION PRECAUTIONS

4.3.1 ROLL LENGTH, MASS, BALANCE, NATURAL FREQUENCY AND TRACKING

The cantilever transducer is ideally suited for narrow web applications. Roll length should generally be limited to 20 Inches. Because the roll is supported only at the transducer end, some inevitable deflection and loss of perpendicularity can occur. For this reason, rolls should be limited in length and mass so as not to unnecessarily increase the transducer moment.

Also keep in mind that the beam assembly internal to the transducer affords a particular mechanical “stiffness” which interacts with a roll’s mass to cause a natural resonant frequency. If the roll spins near the point of resonance, a destructive un-damped vibration can occur. For this reason, it is always advisable to check for this possibility, and either decrease the roll mass (by specifying aluminum or composite rolls), decrease roll RPM (by avoiding small diameter rolls) or by using a higher MWF transducer (affording higher “stiffness”). At higher RPMs, roll balance becomes increasingly important (refer to Section 4.3.2 for a discussion).

Web tracking can be adversely affected when the roll “pitches” because of poor transducer mounting, excessive shaft to transducer bore clearance or shaft bending. It is advisable to consider these issues when specifying transducer-mounting arrangements, roll shaft diameters and roll mounting techniques.

4.3.2 ROLL BALANCE

The sensing roll must be adequately balanced. Understand that the balance of the sensing roll will be more demanding than that typically needed in general rotating machinery. The goal goes beyond just limiting the force to which bearings will be subjected, but rather to minimize the generation of an unintended noise component in the transducer tension signal. The centrifugal force caused by imbalance can be estimated using the following formula:

$$F = (1.77 \times 10^{-6}) \times W \times R \times (\text{RPM})^2$$

Where:

F = centrifugal force (in units of lb-f)

W = weight imbalance (in units of ounces)

R = radius of displacement, distance of imbalance weight from roll axis of rotation (in inches)

RPM = Revolution per minute

The force increase is equal to the square of the RPM, or in other words, doubling the RPM causes four times the imbalance force. If the roll has a high length-to-diameter ratio, two-plane (dynamic) balancing is recommended. Balancing is particularly needed where higher RPMs and lower web forces are involved.

To illustrate how much imbalance induced “noise” could be generated, the following table shows the force disturbance for various ISO balance grades for an illustrative case of a 10 pound roll rotating at 2000 RPM.

Balance Grade (ISO 1940/1)	Residual Imbalance	Resultant Force due to Residual Imbalance
G16	1.25 oz-in	+/- 9 lb-f at 33 Hz
G6.3	0.5 oz-in	+/- 3.5 lb-f at 33 Hz
G2.5	0.2 oz-in	+/- 1.4 lb-f at 33 Hz
G1	0.08 oz-in	+/- 0.6 lb-f at 33 Hz

4.3.3 CRITICAL ROLL SPEED

Even with a balanced roll, a vibration can be set up in a stationary shaft. If this vibration (in cycles per minute) occurs at the harmonic frequency of the shaft, the transducers can be damaged.)

Rotating equipment should never be designed to be operated near critical speeds that risk exciting natural modes of oscillation. Keep in mind that there can be multiple modes, and various components can each have an individual set of natural resonant frequencies.

Aside from the critical speed of the roll itself, the basic mass of the roll assembly and the “stiffness” of the transducer beam interact to exhibit a fundamental frequency.

The columns “Roll Weight” and “RPM with Margin” provide illustration of typical limits for roll mass and roll RPM for each of the major transducer ratings.

Transducer MWFs	Stiffness (lb/in)	Roll weight	Hz	RPM	RPM w margin	Ratio
5	8.33E+02	5	40.4	2422	1800	0.743161
10	1.67E+03	10	40.4	2422	1800	0.743161
25	4.17E+03	15	52.1	3127	2400	0.767533
50	8.33E+03	30	52.1	3127	2400	0.767533
100	1.67E+04	40	63.8	3830	2800	0.731136
100	1.67E+04	50	57.1	3425	2600	0.759047
250	4.17E+04	60	82.4	4944	3600	0.728146
500	8.33E+04	100	90.3	5416	3900	0.720095

4.3.4 AVOIDING DAMAGE TO THE TRANSDUCER

To avoid damaging the transducers, refrain from repetitive overloading above the maximum working force or severe overloading.

4.4 MOUNTING THE TRANSDUCER

The mounting surface for the transducer should be flat and true to the web path. Remove any loose paint, rust or scale from the machine frame before mounting. A clean metallic surface helps ensure that the body of the transducer is at **frame potential**.

Table H – Steps for Mounting an Ultra Series Transducer

If you are using this type of Mounting style:	Then, perform these steps:
Stud (S)	Before tightening the mounting bolt, rotate the transducer body until the force direction (indicated by the arrow on the label) is aligned with the vector of the web force. The vector of the web force is the bisector of the wrap angle. Refer to Figure 12.
Pillow Block and Bearing Replacement (PB, BR)	<ol style="list-style-type: none"> Loosely mount the transducer by lightly tightening the four (4) socket head cap screws that hold the lock plate to the back of the transducer. Rotate the body of the transducer until the direction of the force (indicated by the arrow on the label) is aligned with the vector of the web force. Tighten the four (4) socket head cap screws to securely clamp the transducer in position.
Flange (F)	<ol style="list-style-type: none"> Before drilling the four (4) mounting holes, determine the orientation of the transducer taking into consideration the location of the mounting screws. Be sure that the screws do not interfere with the position of the connector. An optimal location for mounting holes also lets you maximize rotational alignment range. <hr/>  <p>Do not use the flange assembly as a drill template while not mounted to the transducer. The spacing between flange halves is different when the transducer body is added.</p> <hr/> <ol style="list-style-type: none"> Adjust the alignment of the transducer. First, be sure that the four (4) flange bolts are loose and then, loosen the two (2) bolts that draw the flange halves together. Rotate the body of the transducer until the direction of the force, indicated by the arrow on the label, is aligned with the vector of the web force. Secure the flange to the transducer. Tighten the two (2) socket head cap screws that draw the flange halves together. Tighten the four (4) bolts that draw the flange to the mounting surface.

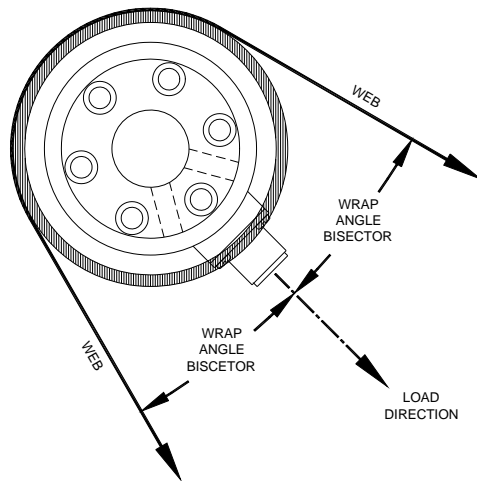

Figure 12 - Proper Orientation of the Cantilever Transducer
 Although this figure shows an Ultra Cantilever transducer, it is also applicable to the Ultra ISC Cantilever transducer.

4.5 MOUNTING THE SENSING ROLL

The following steps take into consideration the risk and difficulty of handling large rolls and help to minimize the number of failed attempts at mounting the roll.

1. Before mounting the sensing roll, confirm that the transducer body is securely mounted.
2. Measure the roll shaft diameter, the shaft adapter bore diameter to be sure that they fit properly.
3. Loosen the two (2) set screws on the shaft adapter.
4. Place the roll shaft into the transducer adapter and tighten the setscrews per the torque specification in Table “E”.

4.6 ORIENTING THE CANTILEVER TRANSDUCER

The Load Line on the transducer must bisect the angle of wrap. This is accomplished when the Cantilevered transducer is oriented as shown in Figure 4 and 5. Rotate the transducer body until the proper alignment is achieved. Generally a visual determination of this orientation is sufficient for most applications

The transducer is designed so that the cantilevered roller used for tension measurement provides the same tension reading for a given web width no matter where the web is positioned along the length of the roller. For example, a 3 inch wide web riding on a 12 inch wide cantilevered roller produces the same tension reading whether the web is centered on the roller or positioned left or right of center. The reading may deviate to a small extent if the alignment is not exact. Optimizing or fine-tuning can be done if required. Consult the factory if you find this is necessary.

Once the transducer is properly oriented, Ensure that the transducer mounts are tightened the per the torque specifications in Table “E”.

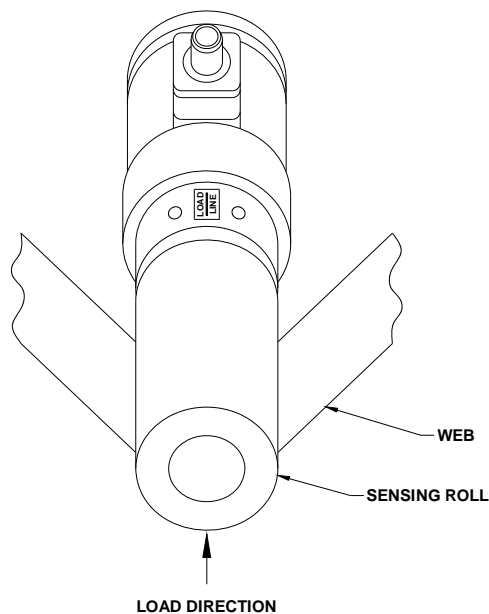

Figure 13 –Transducer load direction Diagram.



This alignment is very important to ensure that the Transducer reads the signal evenly across the whole sensing roll.

4.7 CHECKING THE TRANSDUCER MOUNTING

Before preparing to apply force to the transducer(s) and calibrating the tension controller, inspect the load cell to confirm that it is oriented and mounted in accordance to the installation instructions. Common problems include:

- Failure to mount transducers on flat (machined) surface.
- Shaft length or roll weight that exceeds allowable limits.
- Fastener torque either excessive or insufficient.
- Transducer mis-oriented so that the axis of sensing is not true to the applied force vector (bisector of the wrap angle).
- The transducer is positioned in the web path so that the wrap angle is not constant.

For more information about proper practices for applying calibration, refer to section 4.11 in this document.

4.8 POWER-UP AND TESTING

4.8.1 BEFORE APPLYING POWER

Before applying power, check the wiring to the amplifier. Pay particular attention to the following:



- Double check the transducer cabling to ensure that the 24V power supply is within limits and polarity is correct.
- Use an approved anti-static wrist strap when adjusting any potentiometers on the amplifier.
- Use the appropriate tool when making any adjustments to the potentiometers on the amplifier. Damage to the circuitry may occur if excessive force is used or a conductive tool accidentally contacts internal voltages.

4.8.2 POWER APPLICATION

As soon as practical after connecting power to the ISC, verify that the 24 VDC supply is operational and not overloaded by any mis-wiring. Use a DC voltmeter to confirm that the supply polarity is correct and that the voltage is within the prescribed limits. Promptly identifying any over-voltage condition can help minimize potential damage to the circuitry internal to the transducer.

With 24 VDC supply confirmed, check the DC output voltage reported by the ISC and see if it responds as expected when small test forces are applied to the Tension Transducer.

4.9 ADJUSTMENT TOOLS (ONLY IF NOT USING NUMERICAL CORRECTION)

Using the correct tools simplifies the setup process and necessary adjustments. Keep the following points in mind:

- The Integrated Signal Conditioning Amplifier utilizes two different potentiometers. The Gain and Zero adjustments are located on the side of the amplifier (under the sticker). The adjustment tool should have dimension on the order of 0.5mm (.020 inches) blade thickness and be 2.5 mm wide (0.1inches).
- **Important:** Use a non-conductive tool to alter potentiometer positions. Be sure that adjustment tool does not touch any part of PCB circuit to avoid accidentally damaging it.

4.10 GAIN AND FINE ZERO CALIBRATION

The gain and zero adjustments are preset but accessible by the user for adjustment if absolutely necessary. To make your final calibration adjustments, use the following steps:

1. Verify Zero on the analog Outputs for the “unloaded” (no web force applied) condition and adjust the Zero potentiometer to correct for any minor offset voltage.
2. Apply the calibration force to the transducer(s) and adjust the Gain potentiometer to achieve the desired span.
3. Verify linear operation of the transducer and amplifier by applying a series of forces that falls somewhere between the zero and full-scale endpoints. The intent is not to re-execute any calibration per se, but to confirm the hardware’s ability to accurately report a measured force without non-linearity.

We recommend that you focus only on achieving a particular voltage “span” between the load and unloaded forces by alternating between the two force levels. **Avoid** repeatedly adjust the Zero potentiometer between measurements unless the offset voltage becomes excessive and interferes with achieving a valid output signal on the analog output. You should only adjust the final Zero after the desired Gain setting has been achieved.

These final calibration steps represent the minimal adjustments that might be required at periodic calibration intervals and typically involve only the Zero and Gain potentiometers accessible through the small holes in the front cover.

4.11 PROPER PRACTICES FOR APPLYING CALIBRATION FORCES

Seldom is a transducer oriented such that the calibration can be done by simply hanging a true dead weight from the roll. By generating a tension force that follows the same web path across the roll, you avoid the necessity of making manual (numerical) calculations to correct for the details of different wrap angle, transducer orientation, etc.

The following diagrams show you the correct and incorrect techniques to use when applying calibration forces.

Examples of Inaccurate Wrap Angles

(This figure may not represent the load cell style that you have.)

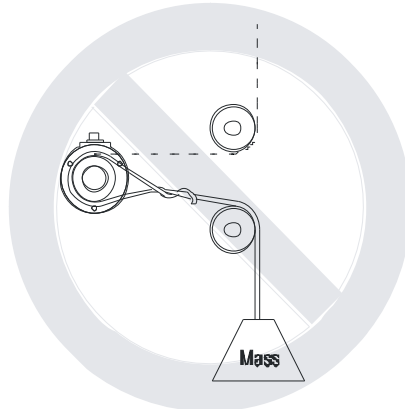

In this example, there was a disregard for maintaining the correct wrap angle. The dotted line indicates the proper web path.

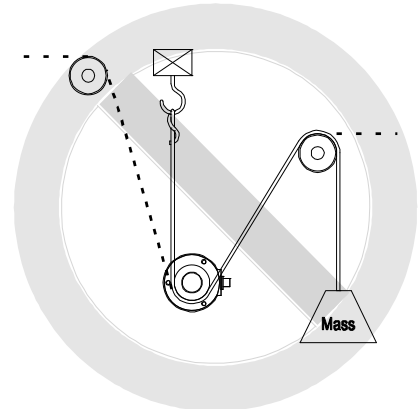

In this example, the true web path was difficult to access and an incorrect path was implemented using a convenient, but incorrect anchor point.

Example of Correct Wrap angles and Anchor Point

(This figure may not represent the load cell style that you have.)

In this example, the anchor point and the wrap angle have been correctly achieved and closely follow the actual web path.

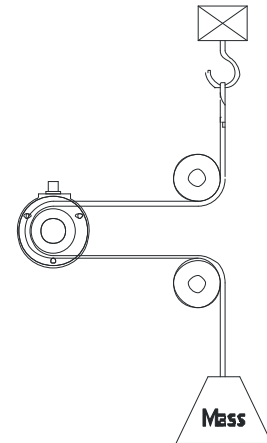

Examples of Force Loss due to Friction at Driven Roll
 (This figure may not represent the load cell style that you have.)

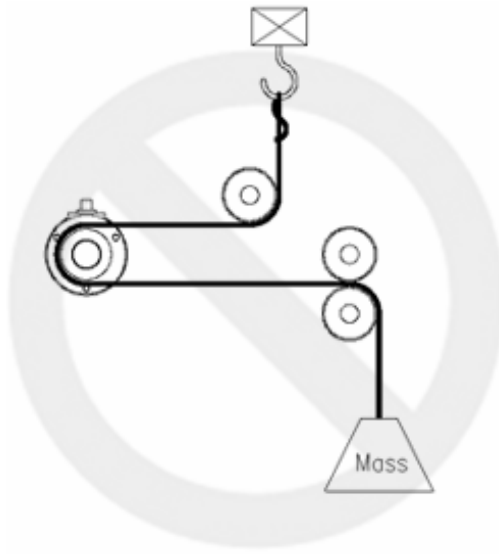

In this example, only a fraction of the test force is transferred to the transducer due to drag from the driven roll.

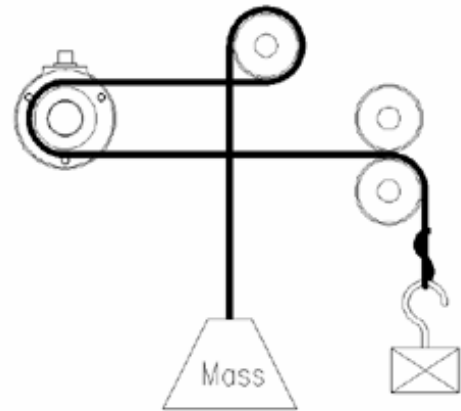

In this example, by rearranging the anchor point and the force location as well as utilizing the idle roll, the frictional losses are minimized.

4.12 APPLYING FORCE TO TRANSDUCERS

The application of an accurate calibration force can be a challenge. Keep the following points in mind:

- Allow the transducer and amplifier to reach thermal equilibrium before conducting calibration. Ideally, the temperature should reflect the expected operating conditions.
- With very low force transducers, consider that connecting a test mass will involve some finite cord mass.



When conducting a calibration that involves a large mass, it is often practical to use a series of smaller masses added in succession. Consider performing an initial Zero and Gain adjustment when the first 20% of the weights have been applied. By performing the calibration using this method, the Zero and Gain adjustments can be made approximately correct earlier in the calibration effort (before many weights have been handled). When the full calibration load is applied, there is a better chance that only minor adjustments will be needed.

4.13 CALIBRATION ACCURACY CONSIDERATIONS

The application of an accurate calibration force requires careful attention to minimizing the non-ideal effects of the real world. Keep the following points in mind:

- Allow the transducer and amplifier to reach thermal equilibrium before conducting calibration. Ideally, the temperature should reflect the expected operating conditions.
- The test force should be a moderate percentage of the intended working force of the transducer and never over the 100% Maximum Working Force (MWF) or, you risk calibrating with an overloaded (“clipped”) transducer signal.
- Cycle the load on the transducer a number of times with the test force to pre-condition or “set” the transducer prior to calibration. Repeat this procedure again before calibrating if the transducer has been disturbed (i.e. roll remounted or any mounting bolts re-torqued).
- With very low force transducers consider that connecting a test mass involves some finite cord mass.
- When two transducers support a roll, calibrate with the cord in the exact center of the roll.

- Passing a cord over a roll on its way to the transducer inevitably causes some amount of friction. The worst case scenario involves passing the working part of a cord over a roll that doesn't readily freewheel. A test was conducted to determine the loss on a stationary 4" diameter anodized roll with a 90 degree wrap angle. It exhibited a 25 to 30% loss in force due to friction!
- When all else is done correctly, the largest remaining contributor to error is friction. If friction cannot be reduced, consider determining the magnitude of the friction through measurement and then making first order corrections numerically.
- Always apply and remove the test load in a continuously increasing or decreasing manner, so that the force changes are monotonic. This helps to avoid disturbing any hysteresis component of the transducers force signal.
- When calibrating for a particularly wide roll that will always have a narrower product tracking to one side, consider applying the calibration force at the roll position that represents the center of the product. This will automatically cancel some of the affects of transducer gain imbalance without the need to actually re-balance the transducers gains within the amplifier.
- It is a good practice to verify linear operation of the transducer and amplifier by applying a final test force that falls somewhere between the zero and full-scale endpoints. The intent is not to conduct calibration, but to confirm the hardware's ability to accurately report a measured force.

4.14 FINAL CALIBRATION

Even though the ISC transducer is factory calibrated, calibration is still usually required **to accommodate application variables such as wrap angle and transducer orientation**. The customer then accesses these software parameters using an HMI, keypad, or other device. The transducer is still calibrated using weights as is done currently.

Final calibration is always generally required to take in to account particular application circumstances of roll weight, wrap angle and load cell orientation. The final zero and span calibration is most easily accomplished by numerical scaling within the digital processor of the tension controller. Because each ISC equipped tension transducer has been factory adjusted for uniform transfer function, load cell interchangeability when calibrated this way is readily promoted.

Field calibration still consists of applying **known forces in the web**, but instead of adjusting a potentiometer, the observed load cell offset is determined at the controller and then numerically subtracted from the reported load cell signal.

In the case of Span calibration, a known web force (equal to a moderate portion of the expected operational force) is applied using test cords routed through the expected web path past the transducer pair. An appropriate numerical scaling factor is then determined and then used as a scaling factor within the tension controller.

Hint

An interesting approach to slightly attenuating the load cell output by purely mechanical means can be used with those load cell styles which accommodate slight rotation relative to the bisector of the wrap angle (i.e. Cartridge transducers and Slim Cells).

Consider taking advantage of the Cosine relationship (noting that the first 10 degree mechanical shift will reduce the output span by 1.5%). The deflection of CMC's strain gage based loadcell is sufficiently small that tracking will not usually be adversely affected.

4.15 EMC CONNECTIONS AND INSTALLATION

Compliance with the specified EMC directive for immunity in a heavy industrial environment and emissions in a light industrial environment requires correct installation and wiring of the Ultra ISC Tension Transducer. The most important precaution to be taken in the wiring is to use double screened (shields) cabling for the cables from the transducers (load-cells) to the controller, and from the 24VDC Power Supply to the transducer load. The outer screen of each cable must be firmly bonded to the enclosure that contains the amplifier, the transducer (load-cell) housing and the enclosure of the output load device. Large loops of unshielded cables must be avoided and effective cable glands providing 360 degree grounding of the outer screen of the transducer and output cables to the enclosure must be used.

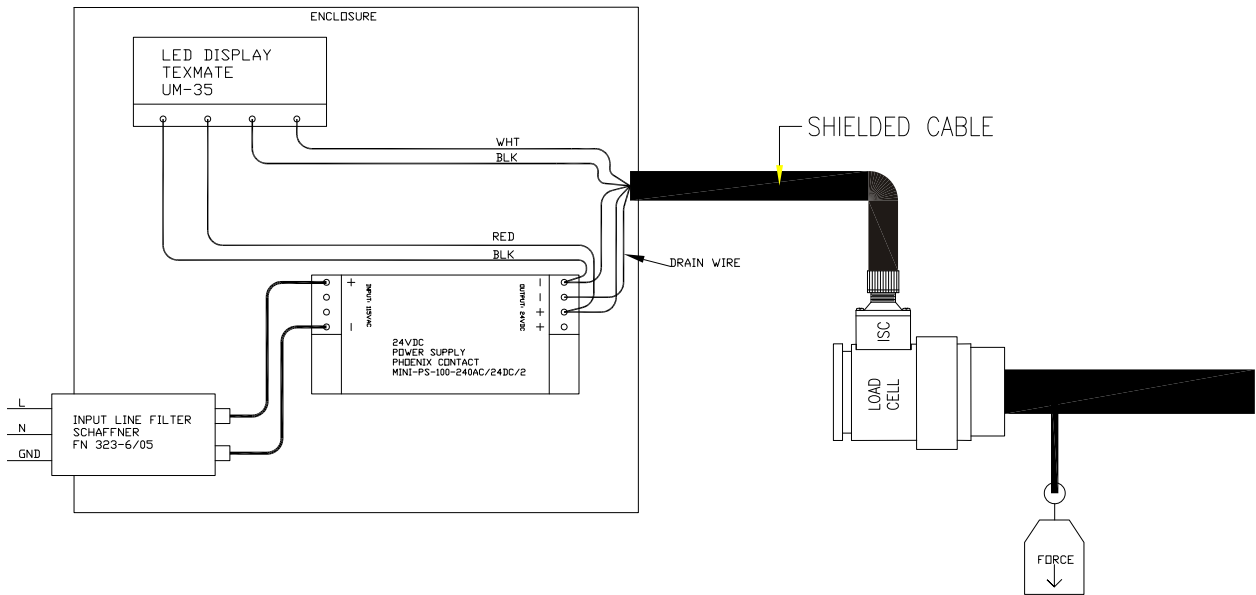

Figure 14 EMC Connections and Installation

4.16 CABLE GLANDS

Several manufacturers provide cable glands that can be used to ensure the integrity of the EMC requirements when installing this equipment in the enclosure. The objective of the cable gland is to provide a good mechanical entry into the enclosure to protect the cable and also provide an electrical bond the outer shield (screen) of the cable to the enclosure.

The following is a list of cable gland vendors and the range of cable sizes that each vendor can provide. This is not an endorsement or promotion of any particular vendor or manufacturer; the information is provided only to assist you in the application of the product described in this document.

Cable Gland Vendor	Cables
Sealcon 14853 E. Hinsdale Ave., Suite D Englewood, CO 80112, U.S.A. Tel: (303)699-1135 Fax: (303)680-5344 Tel: (800)456-9012	EMI-Proof Grounded Nickel Plated Brass Liquid Tight Strain Relief Fittings Standard and Feed-through types Cable diameters from 0.11 inches to 1.38 inches Metric (PG) or NPT thread types Optional metric (PG) to NPT adapters
GlobTek, Inc. 186 Veterans Drive Northvale, NJ 07647 Tel: (207)784-1000 Fax: (210)784-0111 Email: globtek1@idt.net URL: www.globtek.com	Standard, IP68 protection Index EMC Cable Glands Cable diameters from 6.0 mm to 20.0 mm Metric threads
Wiedmuller Tel: (800)849-9343 Fax: (800)794-0252	Bulkhead Cable Glands for Braid/Armour Termination Standard types KGC 1 Series Cable diameters from 1.8 mm to 39.9 mm Metric threads Optional washers and locknuts
Belden	Braided "overshield" wire; Belden #8669 (0.5" I.D.) braided shielding and bonding wire

5 TROUBLESHOOTING



Safety should not be an afterthought. Before installing, servicing or calibrating review and follow applicable policies and procedures to ensure worker safety. Machinery must be in a safe state and be aware of any additional hazards that can arise when installing and calibrating higher force transducers.

The following table provides you with a list of typical issues that you may encounter and possible solutions:

If you are having this issue:	Then:
No Output Signal	<p>Check to be sure that all connections have been made completely and properly. Inspect the connecting cables for crimps or cuts.</p> <p>Verify that the appropriate 24VDC supply voltage is being applied to the ISC tension transducer. Check fuses in supply.</p> <p>Disconnect the ISC tension transducer output wires from the tension controller's input terminals (to eliminate any potential for accidental loading) and check the amplified output signal using a voltage meter.</p>
Low Output Signal	<p>The transducer may have too large a maximum working force (MWF) in relation to the force to be sensed, or the wrap angle may be insufficient and is not able to generate an optimum resultant force on the transducer.</p> <p>Or</p> <p>The transducer may be improperly orientated such that the transducer's axis of sensitivity is not aligned with the bisector of the wrap angle.</p> <p>Or</p> <p>Check the amplifier to confirm that the signals from each ISC transducer will combine additively. Otherwise, the two signals will work against each other, and only minute differences between signals appear.</p>
Wrong Polarity of Output Signal	<p>Transducers may have been incorrectly oriented. Refer to Section for proper load direction. Alternately, change the signal sense by interchanging the white and black transducer leads into the tension controller. Compliment (invert) signal sense in controller software.</p>
Excessive Output Signal with Minimal or No Load	<p>There may be a high degree of misalignment of the transducers causing a severe pre-load.</p> <p>Or</p> <p>The sensing guide roll assembly may be excessively heavy. The sensing guide roll should not weigh more than ½ the maximum working force of the transducers in most cases.</p> <p>Or</p> <p>The transducer may have too small a maximum working force for the application. Replace with a higher maximum working force transducer or decrease the web wrap angle.</p> <p>Also,</p> <p>Check cables and connectors for intended connections using an ohm-meter or continuity checker. Inspect not only for continuity where expected, but also disconnect connectors and check for unintended resistances (shorts) between conductors.</p> <p>Inspect the transducers for mechanical reasons why there is a reported overload. Possibilities include: debris wedged in the transducer's shaft seal area, a roll shaft bottoming inside the transducer body or transducer otherwise poorly mounted.</p>
Poor Linearity	<p>Check for mechanical reasons such as rubbing or binding that interferes with the force being properly transmitted to the load cell.</p> <p>Or</p> <p>Your calibration efforts may have been conducted while either the transducer or the amplifier was in a non-linear mode (i.e. under the effects clipping or saturation). Try and recalibrate the amplifier using a lower force.</p> <p>To determine whether the clipping is being caused by the transducer or the amplifier, apply a series of intermediate forces and record the un-amplified tension signal.</p>

5.1 TRANSDUCER BENCH TESTING

Because the strain gage signal conditioning is completely internal to the transducer, it is impractical to directly measure the resistance of the strain gage elements. This complicates the task of bench testing.

However, there are measurable indications of the potential functionality.

1. Measure the DC load current powering the ISC. An in-line Digital Multi-meter (DMM) set up to measure DC milliamps can be used. With a 24 VDC supply applied, the current into PIN 1 of the M12 connector should be between 25 and 45 milliamps. If no discernable current is observed, check the applied polarity (the voltage to the ISC could be reverse, and the internal polarity protection diode could be blocking current flow). Also check that the DMM is set for DC and not AC milliamps.
2. If the current is reasonable, check the transducer output voltage for zero. Set the DMM back to measuring voltage and amplified output voltage at PIN 2 with respect to PIN 4. With no force being applied to the transducer, the voltage should be within part of a volt of ground. For an un-mounted cartridge style transducer, the ideal “no force” condition can be accomplished by orienting the loadcell so that the roll journal bore faces “skyward”. If the transducer is still machine mounted, and there is a roll mounted, the dead-weight of the roll can be negated by slightly loosening the mounting to allow the loadcell body to be rotated so that the axis of loadcell force sensing is parallel to the ground. With heavy rolls, exercise care before loosening any mounting so that an unsafe condition does not result.
3. If the transducer is of limited M.W.F. , it should be possible to apply forces by hand and observe (in a qualitative way) the amplified output swing to different positive and negative voltages.

If the transducer has a high M.W.F. capacity, the full amount of force may not be readily applied “by hand”, and the following approach can be used to observe the capability of the analog output stage.

It is generally not advisable to needlessly alter the factory calibration of the loadcell, but if necessary, the ZERO potentiometer setting can be used as a way to temporarily drive the transducer output to arbitrary positive and negative voltages to prove that the output stage of the transducer is operational.

After changing the ZERO potentiometer, return it to the desired output voltage with no force applied.

4. Because the ISC is a true analog design, there is no “quantization” of the analog signal and the output has (theoretically) infinite resolution. It is therefore possible that high MWF transducers can be checked with a DMM set to the millivolt scale and series of relatively small test forces applied with either masses or a hardware store variety “fish scale”. For example, a 1000 lb transducer should have a calibrated slope of 1.6 oz / mV. With just a handful of appropriately weighted items (quantified using a shipping scale) it is possible to conduct a crude test of a transducer to verify that it exhibits an essentially rational transfer function.
5. Using a DMM set to measure high resistances, test between the M12-3 and M12-4 pins to verify that the 24 VDC supply is galvanically isolated from the analog signal conditioning stage as evidenced by a resistance above 20 Mohm.
6. As a final electrical test, a DMM should be used to check the resistance between each of the M12 connector pins and the metallic case of the transducer. No pins should have less than 20 meg-Ohm (this is a typical measurement limit of most Multimeters). DO NOT use a high voltage insulation tester (i.e. “megger”) to test for the high resistance, as this can cause damage to the internal circuitry. Exercise care that ungloved fingers do not simultaneously contact the two meter probes, or the resistance measurement will be falsely low due to the conductance of human skin.

6 MANUFACTURERS DECLARATION OF CONFORMITY



Cleveland Motion Controls

EC Declaration of Conformity

Value Center
7550 Hub Parkway • Cleveland, OH 44125-5794
PHONE (216) 524-8800 • FAX (216) 642-2199

We hereby declare that the following product is in conformity with the requirements of the following EC Directives:

Product: **Ultra ISC Tension Transducer Product Line**

Type: **Signal Conditioning Amplifier for Tension Transducers**

The product is designed and manufactured in accordance with the following standards.

EMC Directive: **EN 61326:2006 Electrical equipment for measurement, control and laboratory use — EMC requirements**

Test Results

Test Procedure	Description	Result
55011	Radiated Emission	Pass
61000-4-2	Electrostatic Discharge	Pass
61000-4-3	Radiated Immunity	Pass
61000-4-4	Fast Burst Transients	Pass
61000-4-5	Surge	Pass
61000-4-6	Conducted Immunity	Pass
61000-4-8	Magnetic Immunity	Pass

Manufacturer and Authorized Representative: **ITT Cleveland Motion Controls
7550 Hub Parkway
Cleveland, Ohio U.S.A 44125-5794**

Date: 11/26/08

Signed: *E. Wayne Foley*

Wayne Foley
President
ITT Cleveland Motion Controls

AO-90452AA

Engineered for life