

CLEVELAND-KIDDER®

**UNDER PILLOW BLOCK
WASHDOWN-DUTY
LOAD CELL**

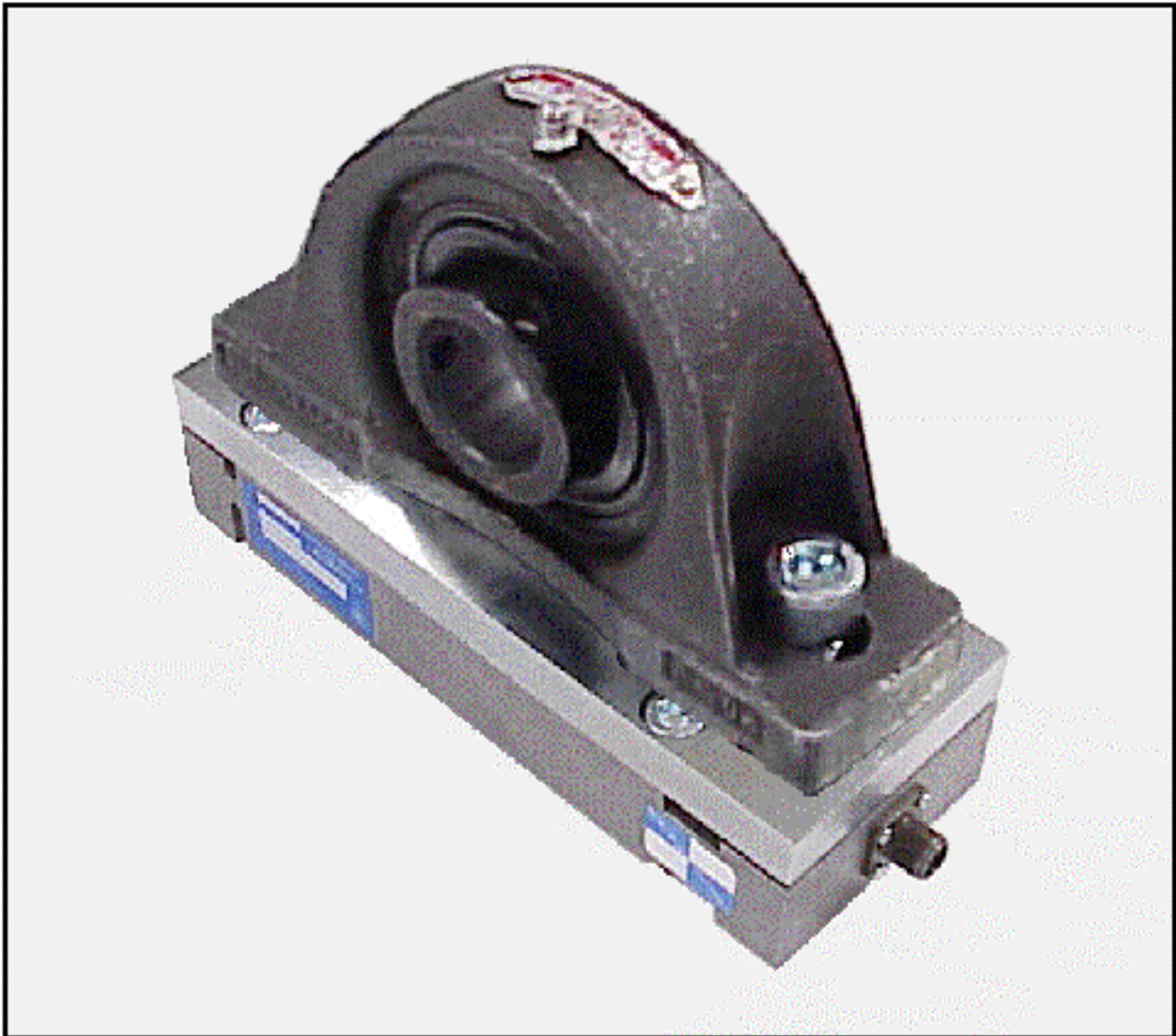

INSTRUCTION MANUAL . . . TYPE UPB WASHDOWN-DUTY



7550 Hub Parkway
Cleveland, Oh 44125-5794
Phone: 216-524-8800
Or 800-321-8072
Fax: 216-642-2100

Visit Us: www.cmcontrols.com



1.0 GENERAL INFORMATION

1.1 RECEIVING AND UNPACKING

Handle and unpack the equipment carefully. Immediately upon arrival, check the shipment against the packing list. Any damage should be reported immediately to the carrier and to the nearest CMC representative.

Equipment that will not be installed immediately should be stored in a clean, dry location. Precautions should be taken to prevent moisture, dust and dirt from accumulating in storage and installation areas

1.2 PRECAUTIONS

1.2.1 Shipping - It is recommended that the sensing roll be removed when the machine is shipped with the transducers mounted. The shock and vibration transmitted to the transducers by the sensing roll during transporting can damage them.

1.2.2 Roll Balance - The sensing roll should be balanced to prevent forces caused by imbalance. These forces cause a noise signal to be superimposed on the tension signal. The centrifugal force (F) caused by imbalance can be calculated using the equation below.

$$F = 28.6 \times 10^{-6} \times W \times R \times (\text{RPM})^2 \text{ Lbs.}$$

W = Weight of roll in pounds

R = Displacement of mass of roll from the axis of rotation in inches

RPM = Revolution per minute

It is recommended that the force (F) be less than 5% of the resultant web force at the maximum web speed for most applications.

1.2.3 Critical Roll Speed - Even with a balanced roll, a vibration can be set up in a stationary shaft. If this vibration (in cycles per minute) occurs at the harmonic frequency of the shaft, the transducers can be damaged. To determine the critical roll speed, use the following formula:

$$\text{Critical roll speed in RPM} = \frac{4.8 \times 10^6 \times \text{Shaft O.D.}}{(\text{Shaft Length})^2}$$

Dimensions are in inches.

To assure that this problem is avoided, the critical roll speed should at least be 20% above the roll speed attained at maximum web speed.

1.2.4 Overloading - Repetitive overloading above the maximum working force or severe overloading should be avoided because it will damage the transducers.

1.3 SPECIFICATIONS

Gage Resistance - End to end resistance 440-480 Ohms

Gage Factor - 100 nominal

Excitation Voltage - 10 VDC or VAC (RMS) maximum

Output Signal at Rated MWF - 100 mV nominal per Transducer (1/2 bridge)
200 mV nominal per Transducer pair (full bridge)

Output Impedance - Approximately 880 Ohms for UPB2 and UPB3
Approximately 120 for UPB 1

Required Input Impedance of Tension Amplifier - 5K ohms per Transducer (1/2 bridge)

Maximum Voltage, Gage to Beam or Base (Ground) - 50 VDC

Operating Temperature Range - 0 F to +200 F

 Compliant

1.4 DESCRIPTION

The Cleveland-Kidder Washdown Duty UPB transducers utilize a sensing twin beam to which semiconductor strain gages are bonded. With these high output signal gages a very small force on the sensing beam will be shown as a change in the tension signal.

The type UPB transducers are for use with shafts that are mounted in Pillow Block Bearings. See Figure 1. For mounting dimensions see Figure 2.

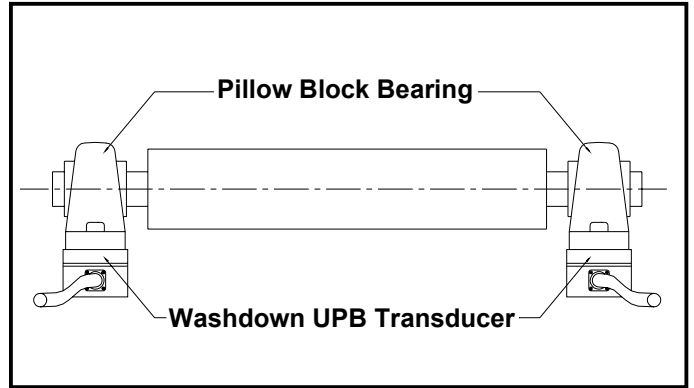
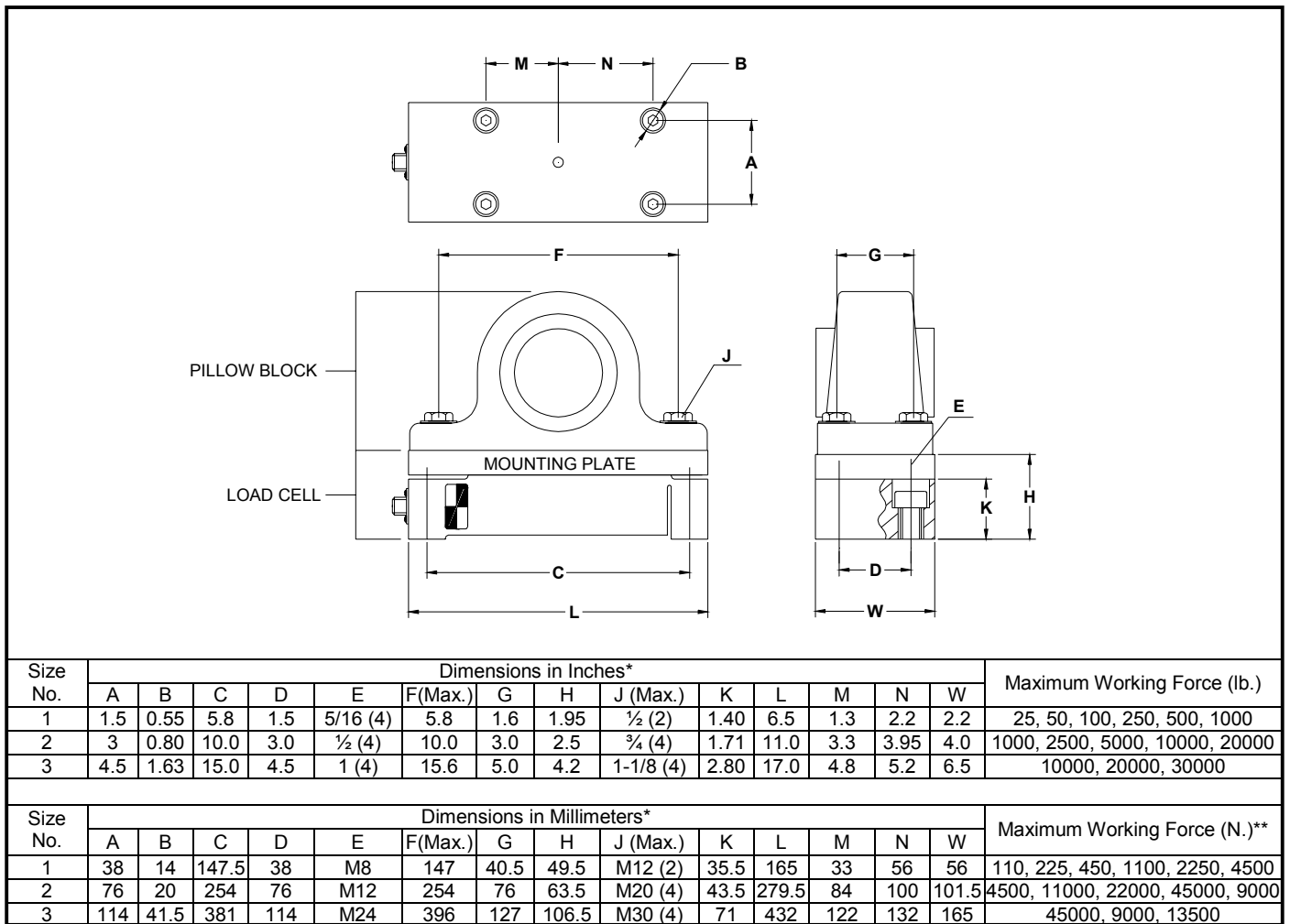

Figure 1



*Allow 2.5 inches (64 mm) clearance for connector

**Approximate rating in Newtons

Figure 2

2.0 INSTALLATION

2.1 SELECTION OF TRANSDUCER MOUNTING LOCATION

When selecting a transducer mounting location, keep in mind that the tension-sensing roll must NOT be mounted where the web wrap angle can vary. Any change in the wrap angle will be sensed by the transducers as a change in tension, and indicated as such on the tension indicator.

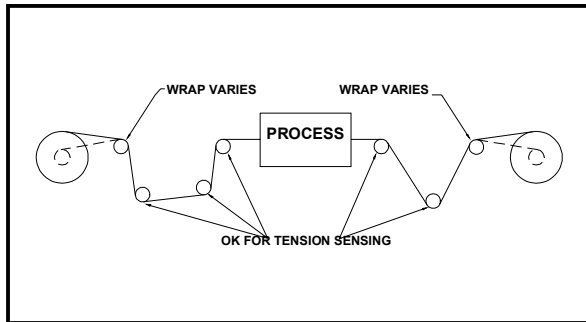

Figure 3

In some cases, it may be impossible to find a location for the transducers where the wrap angle does not vary. The change in indicated tension that will result can be calculated and, if small, may not be significant.

2.2 MOUNTING SURFACE PREPARATION

The mounting surfaces for the transducers should be flat and parallel. Prepare the machine frames or mounting surfaces by removing any loose paint, rust, scale, etc.

2.3 INSTALLATION PRECAUTIONS

To insure proper installation and operation of the system, the following steps should be performed in sequence. Failure to do so could seriously damage the Transducers and void the warranty.

PRECAUTION

Always install, orient and firmly bolt down the transducers **BEFORE** installing the tension-sensing roll. When disassembling or installing, **DO NOT** remove the transducer and the tension-sensing roll as an assembly - remove the roll first, before loosening the transducer mounting bolts.

2.4 INSTALLATION OF TYPE UPB TRANSDUCERS

Instructions for Mounting the UPB Load Cell to the Machine Frame (see Figure 6)

Remove the pillow block mounting plate (it is held in place by four stainless steel corner bolts) in order to gain access to the four load cell mounting holes. Drill and tap the machine frame to match the load cell mounting holes (refer to section 2.5 to properly position the load cell). Bolt the load cell in place. The UPB load cell is designed so that either imperial or metric mounting bolts can be used when mounting the load cell to the machine frame. Refer to E in the **Figure 2** above for the proper bolt size. Before remounting the pillow block mounting plate, refer to section 2.6.

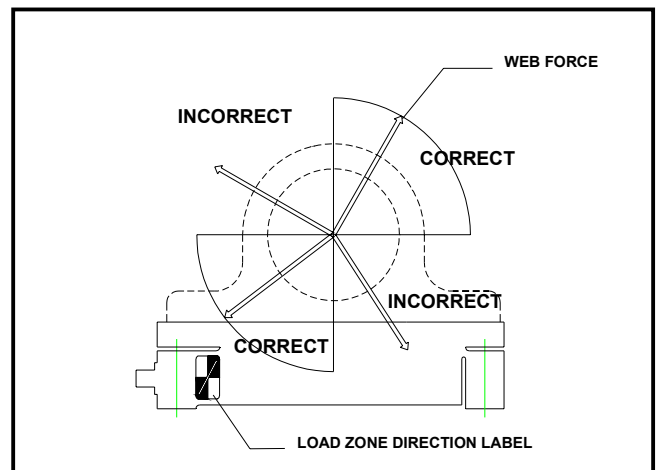

Figure 4

2.5 POSITIONING THE TRANSDUCER

Once the four tapped holes have been drilled, you need to orient the UPB load cell properly to obtain

a good tension measurement. See **Figure 4** for details.

Note: the UPB must be oriented so that the resultant tension force direction (bisector of the wrap angle) is in the same quadrant as the load direction arrow on the side of the UPB.

Once the correct orientation is selected, you need to tighten four locking bolts (not supplied) accordingly to **Figure 5**.

UPB	English		Metric	
	Length min. (in.)	Torque (ft.-lbs.)	Length min. (mm)	Torque (N-m)
1	1.00	10	25	15
2	1.50	30	40	40
3	2.50	150	65	200

Figure 5

2.6 INSTALLATION OF PILLOW BLOCK BEARING

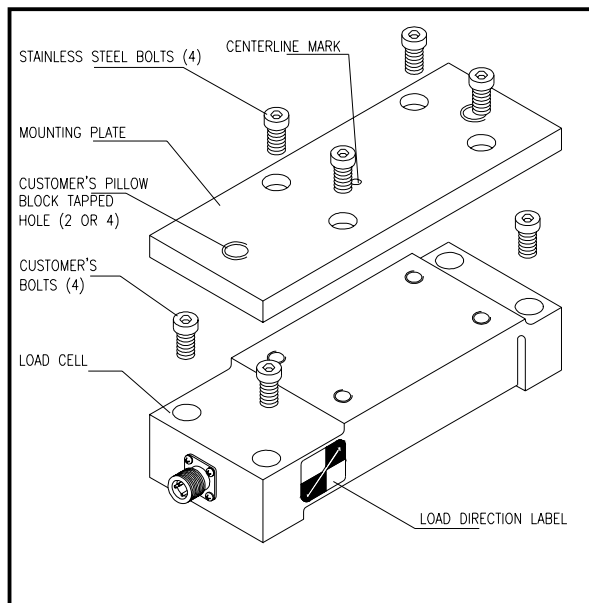

Figure 6

Instructions for Mounting the Pillow Block Bearing to the UPB Load Cell (see **Figure 6**)

Mounting the pillow block bearing to the UPB is simple and convenient. The UPB is shipped with a pillow block mounting plate. The mounting plate is held in place by four stainless steel corner bolts.

Remove the mounting plate, then drill and tap it to match the pillow block mounting dimensions. A centerline mark is provided on the mounting plate. The plate is to be drilled and tapped by utilizing this centerline mark to insure that the pillow block bearing is centered on the plate. Remount the plate and bolt the pillow block bearing to it. The mounting plate is 304 Stainless Steel, which is amenable to drilling but offers corrosive and chemical resistance. Refer to J in the table above for the maximum bolt diameter recommended for bolting the pillow block bearing to the mounting plate.

2.7 EXTREMELY SEVERE APPLICATIONS

For applications that can create major build-ups of material (paint, glue...), it is recommended to close the exposed gaps of the transducer. A good way to do this is to use Electrical Tape all around the side of the UPB Transducer (See figure 7).

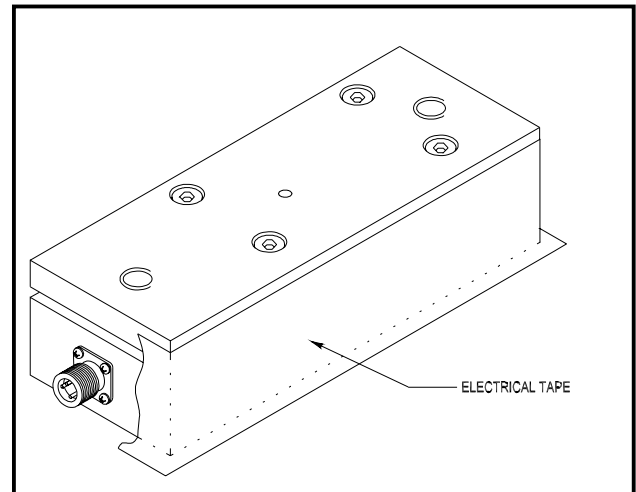

Figure 7

2.8 SHAFT EXPANSION

If the roller is subjected to higher temperatures after installation, thermal shaft expansion may damage the transducers. To prevent damage to the transducers, an expansion type pillow block bearing should be used.

3.0 ELECTRICAL CONNECTION

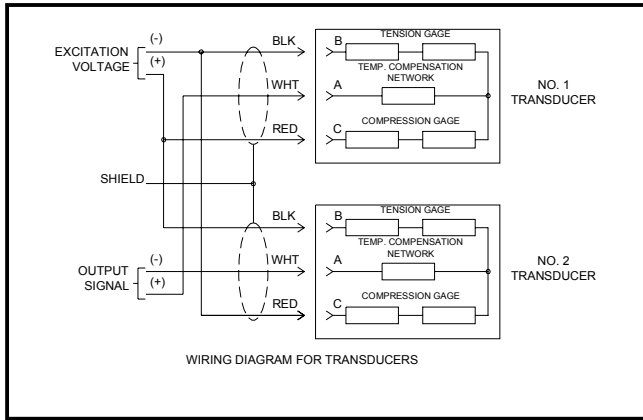

Figure 8

Refer to the installation wiring diagrams supplied with the Cleveland-Kidder tension indicator or controller for making the transducer connections. Make certain that the cables do not interfere with the web path and that they are away from gearing or other moving parts.

Many of the Cleveland-Kidder indicators and controllers use only half bridge transducer inputs and then sum the two transducer signals internally. See the applicable installation wiring diagrams for the tension indicator or controller.

3.1 MATING CONNECTORS FOR TRANSDUCERS

USE CMC P/N

Mating Straight Connector, Boot and Clamp Kit	MO-09854
Mating 90 Angle Connector, Boot and Clamp Kit	MO-09855

These are not sealed for washdown duty. For washdown duty mating connector consult CMC.

3.2 INTRINSICALLY SAFE TRANSDUCERS

These transducers are intrinsically safe only when they are part of a complete intrinsically safe

system using the TIX-1 tension indicator or wired per CMC control drawings.

Barrier block assemblies and/or the individual barrier blocks may be purchased from CMC. Please contact CMC for part numbers and pricing.

4.0 TEMPERATURE COMPENSATION

The transducers are supplied with a temperature compensation network (except size 1 which don't require it) which is in series with the output signal lead. The compensation circuit is designed to be used with a tension amplifier which has an input impedance of 10K Ohms when a pair of transducers connected as a full bridge is used. If only one transducer is used, the tension amplifier impedance should be 5K Ohms. If other than the input impedances given above are used, drift will occur in the tension amplifier output when the transducer temperature changes.

5.0 SINGLE TRANSDUCER OPERATION

For those applications where only one transducer is required, a dummy circuit may or may not be required depending upon the input circuit of the tension amplifier. Consult the factory for this information. The dummy circuit consisting of two resistors is substituted in place of the second transducer. The resistors should have a resistance value between 100 and 150 Ohms and should be matched to within 1%. Dummy circuits are available from the factory for connecting to tension indicators or controllers.

6.0 TROUBLESHOOTING

6.1 EXCESSIVE OUTPUT SIGNAL WITH NO LOAD

There may be a high degree of misalignment of the transducers causing a severe pre-load.

Or

The sensing guide roll assembly may be excessively heavy. The sensing guide roll should

not weigh more than ½ the maximum working force of the transducers in most cases.

Or

The surface under the UPB is not flat enough.

Or

The bolting torque is not in accordance with Figure 5 (especially for UPB with MWF under 250 lb.).

6.2 LOW OUTPUT SIGNAL

The transducer may have too large a maximum working force for the application. Replace with a lower maximum working force transducer or increase web wrap angle.

6.3 WRONG POLARITY OF OUTPUT SIGNAL

Transducers may have been incorrectly oriented. See Section 2.4 for proper load direction. Alternately, change the transducer excitation voltage by interchanging the B and C connections.

6.4 OUTPUT SIGNAL NOT LINEAR, ZERO SHIFTS DURING OPERATION

Check transducer and tension roll mounting. All mounting bolts must be tight. Check that there is no dirt or foreign matter interfering with the transducer mounting. Check that mounting surface is flat and rigid.

6.5 NO OUTPUT SIGNAL

Check to see that all connections have been made completely. Check for places where the connecting cables might be crimped or cut.

6.6 VERY HIGH OUTPUT WITH NO LOAD

Check cables and connectors for good connections and check continuity of cables with an ohmmeter. Check for proper wiring to transducers. Check transducer gage resistance as given in the following chart at room temperature with no load applied.

TRANSDUCER GAGE RESISTANCE CHECK

Resistance (ohms)	UPB 1	UPB 2/3
Pin C to B	420±20	420±20
Pin A to B	210±10	900-1100
Pin A to C	210±10	900-1100

7.0 SERVICE ASSISTANCE AND REPAIR

For additional service assistance, please obtain the Type, MWF, and Serial Number from the nameplate. Contact the Factory Service Department.

Phone: 216-524-8800
Or 800-321-8072
Fax: 216-642-2100

Visit Us: www.cmcontrols.com

Disassembly by improperly trained personnel may result in additional damage to these units. Should repairs be required or for warranty repairs, contact the Customer Service Department for a return authorization number before returning the units.

8.0 USEFUL SPECIFICATIONS

8.1 WEIGHT

	Weight lb. (kg.) Each		
	UPB 1	UPB 2	UPB 3
Complete Unit	3.7 (1.7)	22 (10)	102 (47)
Without mounting plate	1.5 (0.7)	12 (5.4)	59 (27)

8.2 RATINGS

SIZE	RATING (LB)	* ULTIMATE OVERLOAD (%)
UPB 1	25 to 1000	500
UPB 2	1000 to 10000	500
	20000	250
UPB 3	10000 to 30000	500

* Ultimate overload: Maximum force applied on the transducer without risking permanent deformation. For the Washdown duty UPB the output is linear up to the point of the ultimate overload.

8.3 SIZING CALCULATION

T = Max Tension
 A = Wrap Angle (degrees)
 W = Roll Weight
 B = Angle of tension force
 K = Overload for Transients
 (Nominally 1.4 for most applications)
 MWF = Maximum Working Force
 (This is used to select the proper force rating of the transducer)
 C = Mounting Angle
 H = Bearing Height + D

SIZE	L (in)	D (in)
UPB 1	2.5	0.98
UPB 2	4.5	1.25
UPB 3	6.5	2.10

See figure 9.

$$MWF^* = \frac{2KT \sin \frac{A}{2} [H \sin B + L \cos B] \pm W [L \cos C - H \sin C]}{2L}^{**}$$

SIZING CALCULATION:

- * The MWF calculation defines the force on each individual load cell.
 ** If Angle b is below horizontal use + in calculation
 If Angle b is above horizontal use - in calculation

Note: Consult CMC for assistance in sizing the load cell to your specific application.

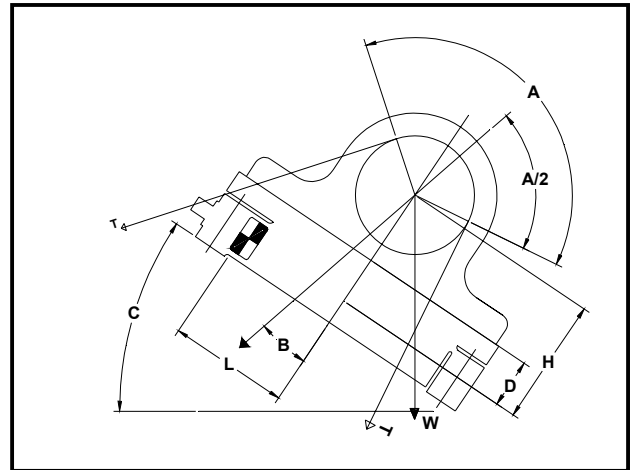

Figure 9

8.4 SELECTION CHART

Transducer	MWF (lbs.)						
	Rating	25	50	100	250	500	1000
UPB1	M846-12171-	000	100	200	300	400	500
UPB2	M846-12172-	000	100	200	300	400	
UPB3	M846-12173-	000	100	200			

Ordering procedure:

1. Calculate the Maximum Working Force (MWF) rating based upon your calculations from the sizing calculation equation.
2. From the Selection Chart, determine the part number for the UPB Washdown-Duty LC. Select a MWF rating that equals or exceeds the MWF from your sizing calculation. Then, make sure that your pillow block bearing fits the UPB type that you selected (UPB 1, 2 or 3).

Example: If you calculate a MWF of 2,204 lbs., select a UPB 2 rated at 2500 lbs. MWF from the Selection Chart. You part number is M846-12172-100. Then, from Figure 2, make sure that you pillow block bearing fits on the Size 2 transducer. If it does not, please consult factory.

3. Obtain pricing and delivery information by contacting a CMC sales representative, distributor, or the factory.

LIMITED WARRANTY.

ALL GOODS ARE SOLD SUBJECT TO THE MUTUAL AGREEMENT THAT THEY ARE WARRANTED BY THE COMPANY TO BE FREE FROM DEFECTS IN MATERIAL AND WORKMANSHIP FOR ONE YEAR FROM THE DATE OF SHIPMENT. THE COMPANY'S WARRANTY DOES NOT COVER, AND IT MAKES NO WARRANTY WITH RESPECT TO ANY DEFECT, FAILURE, DEFICIENCY OR ERROR WHICH IS:

- A) NOT REPORTED TO THE COMPANY WITHIN THE APPLICABLE WARRANTY PERIOD; OR
- B) DUE TO MISAPPLICATION, MODIFICATION, DISASSEMBLY, ABUSE, MISUSE, IMPROPER INSTALLATION, UNAUTHORIZED REPAIR, IMPROPER MAINTENANCE OR ABNORMAL CONDITIONS OF TEMPERATURE, DIRT OR CORROSIVE MATTER; OR
- C) DUE TO OPERATION, EITHER INTENTIONAL OR OTHERWISE, ABOVE RATED CAPACITIES OR IN AN OTHERWISE IMPROPER MANNER.

THE FOREGOING WARRANTY IS IN LIEU OF ALL OTHER WARRANTIES. THE PARTIES AGREE THAT THE IMPLIED WARRANTIES OF MERCHANTABILITY AND FITNESS FOR A PARTICULAR PURPOSE AND ALL OTHER WARRANTIES, EXPRESS OR IMPLIED, ARE EXCLUDED FROM THE SALE OF GOODS.

LIMITATION OF REMEDY AND LIABILITY.

THE REMEDY PROVIDED HEREIN IS BUYER'S SOLE AND EXCLUSIVE REMEDY. **THE BUYER'S REMEDY AND THE COMPANY'S LIABILITY (WHETHER UNDER THE THEORIES OF BREACH OF WARRANTY, CONTRACT, TORT INCLUDING NEGLIGENCE OR STRICT LIABILITY OR ANY OTHER LEGAL THEORY) SHALL BE LIMITED EXCLUSIVELY AT THE COMPANY'S OPTION TO REPLACING OR REPAIRING WITHOUT CHARGE AT THE COMPANY'S FACTORY OR ELSEWHERE ANY MATERIAL OR WORKMANSHIP DEFECTS WHICH BECOME APPARENT WITHIN ONE YEAR FROM THE DATE ON WHICH THE GOODS WERE SHIPPED.** THE COMPANY SHALL NOT BE LIABLE FOR SPECIAL, INCIDENTAL OR CONSEQUENTIAL DAMAGES OF ANY KIND INCLUDING BUT NOT LIMITED TO DAMAGES FOR LOSS OF USE, INCOME OR PROFIT, OR LOSSES SUSTAINED AS A RESULT OF INJURY (INCLUDING DEATH) TO ANY PERSON OR DAMAGES TO PROPERTY. THE COMPANY SHALL HAVE NO LIABILITY FOR DAMAGES OF ANY KIND ARISING FROM THE INSTALLATION AND/OR USE OF THE GOODS BY ANYONE. BY THE ACCEPTANCE OF THE GOODS, THE BUYER SHALL ASSUME ALL LIABILITY FOR ANY DAMAGES WHICH MAY RESULT FROM USE OR MISUSE BY THE BUYER, ITS EMPLOYEES OR BY OTHERS.